

SECTION **INT**
INTERIOR

A
B
C
D
E
F
G
H
I
INT
K
L
M
N
O
P

CONTENTS

PRECAUTION	3	REAR SUNSHADE SYSTEM	11
PRECAUTIONS	3	Wiring Diagram	11
Precaution for Supplemental Restraint System (SRS) "AIR BAG" and "SEAT BELT PRE-TENSIONER"	3	BASIC INSPECTION	17
Precaution Necessary for Steering Wheel Rotation after Battery Disconnect	3	DIAGNOSIS AND REPAIR WORK FLOW	17
Precaution for Procedure without Cowl Top Cover.....	4	WorkFlow	17
Precaution for Work	4	DTC/CIRCUIT DIAGNOSIS	18
PREPARATION	5	POWER SUPPLY AND GROUND CIRCUIT	18
PREPARATION	5	REAR SUNSHADE CONTROL UNIT	18
Special Service Tools	5	REAR SUNSHADE CONTROL UNIT : Diagnosis Procedure	18
Commercial Service Tools	5	REAR SUNSHADE SWITCH	19
CLIP LIST	6	Component Function Check	19
Clip List	6	Diagnosis Procedure	19
SYSTEM DESCRIPTION	7	Component Inspection	20
COMPONENT PARTS	7	REVERSE SIGNAL CIRCUIT	21
REAR SUNSHADE SYSTEM	7	Component Function Check	21
REAR SUNSHADE SYSTEM : Component Parts Location	7	Diagnosis Procedure	21
REAR SUNSHADE SYSTEM : Component Description	7	SYMPTOM DIAGNOSIS	22
SYSTEM	9	REAR SUNSHADE DOES NOT OPERATE	22
REAR SUNSHADE SYSTEM	9	Diagnosis Procedure	22
REAR SUNSHADE SYSTEM : System Diagram.....	9	REAR SUNSHADE DOES NOT OPEN WHEN SELECTOR LEVER IS SHIFTED TO THE "R" POSITION	23
REAR SUNSHADE SYSTEM : System Description	9	Diagnosis Procedure	23
ECU DIAGNOSIS INFORMATION	10	SQUEAK AND RATTLE TROUBLE DIAGNOSES	24
REAR SUNSHADE CONTROL UNIT	10	Work Flow	24
Reference Value	10	Inspection Procedure	26
WIRING DIAGRAM	11	Diagnostic Worksheet	28
		REMOVAL AND INSTALLATION	30

FRONT DOOR FINISHER	30	REAR WHEEL HOUSE GARNISH	41
Exploded View	30	REAR WHEEL HOUSE GARNISH : Removal and Installation	41
FRONT DOOR FINISHER	30	REAR PILLAR FINISHER	42
FRONT DOOR FINISHER : Removal and Installation	31	REAR PILLAR FINISHER : Removal and Installation	42
FRONT DOOR SASH INNER COVER	32	REAR PARCEL SHELF FINISHER	43
FRONT DOOR SASH INNER COVER : Removal and Installation	32	Exploded View	43
REAR DOOR FINISHER	33	Removal and Installation	43
Exploded View	33	FLOOR TRIM	45
REAR DOOR FINISHER	33	Exploded View	45
REAR DOOR FINISHER : Removal and Installation	33	Removal and Installation	45
REAR DOOR SASH INNER COVER	35	HEADLINING	48
REAR DOOR SASH INNER COVER : Removal and Installation	35	Exploded View	48
BODY SIDE TRIM	36	Removal and Installation	49
Exploded View	36	TRUNK ROOM TRIM	53
FRONT PILLAR GARNISH	36	Exploded View	53
FRONT PILLAR GARNISH : Removal and Installation	36	TRUNK REAR PLATE	53
KICKING PLATE OUTER	37	TRUNK REAR PLATE : Removal and Installation...	54
KICKING PLATE OUTER : Removal and Installation	37	TRUNK FINISHER FRONT	54
KICKING PLATE INNER	37	TRUNK FINISHER FRONT : Removal and Installation	54
KICKING PLATE INNER : Removal and Installation	38	TRUNK SIDE FINISHER	54
DASH SIDE FINISHER	38	TRUNK SIDE FINISHER : Removal and Installation	54
DASH SIDE FINISHER : Removal and Installation	38	REAR SEATBACK CENTER FINISHER	55
BODY SIDE WELT	39	REAR SEATBACK CENTER FINISHER : Removal and Installation	55
BODY SIDE WELT : Removal and Installation	39	TRUNK LID TRIM	56
CENTER PILLAR LOWER GARNISH	40	Exploded View	56
CENTER PILLAR LOWER GARNISH : Removal and Installation	40	Removal and Installation	56
CENTER PILLAR UPPER GARNISH	40	REAR SUNSHADE ASSEMBLY	58
CENTER PILLAR UPPER GARNISH : Removal and Installation	40	Exploded View	58
		Removal and Installation	58
		REAR SUNSHADE SWITCH	59
		Exploded View	59
		Removal and Installation	59

PRECAUTIONS

< PRECAUTION >

PRECAUTION

PRECAUTIONS

Precaution for Supplemental Restraint System (SRS) "AIR BAG" and "SEAT BELT PRE-TENSIONER"

INFOID:000000006046611

The Supplemental Restraint System such as "AIR BAG" and "SEAT BELT PRE-TENSIONER", used along with a front seat belt, helps to reduce the risk or severity of injury to the driver and front passenger for certain types of collision. This system includes seat belt switch inputs and dual stage front air bag modules. The SRS system uses the seat belt switches to determine the front air bag deployment, and may only deploy one front air bag, depending on the severity of a collision and whether the front occupants are belted or unbelted. Information necessary to service the system safely is included in the "SRS AIR BAG" and "SEAT BELT" of this Service Manual.

WARNING:

- To avoid rendering the SRS inoperative, which could increase the risk of personal injury or death in the event of a collision that would result in air bag inflation, all maintenance must be performed by an authorized NISSAN/INFINITI dealer.
- Improper maintenance, including incorrect removal and installation of the SRS, can lead to personal injury caused by unintentional activation of the system. For removal of Spiral Cable and Air Bag Module, see the "SRS AIR BAG".
- Do not use electrical test equipment on any circuit related to the SRS unless instructed to in this Service Manual. SRS wiring harnesses can be identified by yellow and/or orange harnesses or harness connectors.

PRECAUTIONS WHEN USING POWER TOOLS (AIR OR ELECTRIC) AND HAMMERS

WARNING:

- When working near the Air Bag Diagnosis Sensor Unit or other Air Bag System sensors with the ignition ON or engine running, DO NOT use air or electric power tools or strike near the sensor(s) with a hammer. Heavy vibration could activate the sensor(s) and deploy the air bag(s), possibly causing serious injury.
- When using air or electric power tools or hammers, always switch the ignition OFF, disconnect the battery, and wait at least 3 minutes before performing any service.

Precaution Necessary for Steering Wheel Rotation after Battery Disconnect

INFOID:000000006046612

NOTE:

- Before removing and installing any control units, first turn the push-button ignition switch to the LOCK position, then disconnect both battery cables.
- After finishing work, confirm that all control unit connectors are connected properly, then re-connect both battery cables.
- Always use CONSULT-III to perform self-diagnosis as a part of each function inspection after finishing work. If a DTC is detected, perform trouble diagnosis according to self-diagnosis results.

For vehicle with steering lock unit, if the battery is disconnected or discharged, the steering wheel will lock and cannot be turned.

If turning the steering wheel is required with the battery disconnected or discharged, follow the operation procedure below before starting the repair operation.

OPERATION PROCEDURE

1. Connect both battery cables.

NOTE:

Supply power using jumper cables if battery is discharged.

2. Turn the push-button ignition switch to ACC position.
(At this time, the steering lock will be released.)
3. Disconnect both battery cables. The steering lock will remain released with both battery cables disconnected and the steering wheel can be turned.
4. Perform the necessary repair operation.

PRECAUTIONS

< PRECAUTION >

5. When the repair work is completed, re-connect both battery cables. With the brake pedal released, turn the push-button ignition switch from ACC position to ON position, then to LOCK position. (The steering wheel will lock when the push-button ignition switch is turned to LOCK position.)
6. Perform self-diagnosis check of all control units using CONSULT-III.

Precaution for Procedure without Cowl Top Cover

INFOID:000000006046613

When performing the procedure after removing cowl top cover, cover the lower end of windshield with urethane, etc.

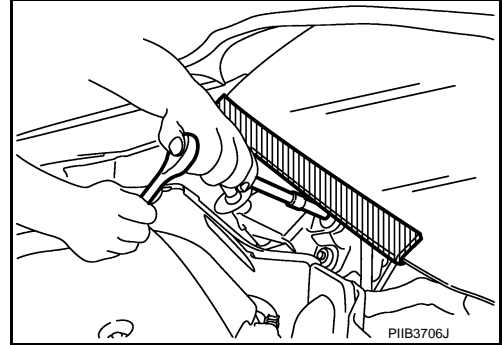

Precaution for Work

INFOID:000000006046562

- After removing and installing the opening/closing parts, be sure to carry out fitting adjustments to check their operation.
- Check the lubrication level, damage, and wear of each part. If necessary, grease or replace it.

PREPARATION

< PREPARATION >

PREPARATION

PREPARATION

Special Service Tools

INFOID:000000006046563

The actual shapes of Kent-Moore tools may differ from those of special service tools illustrated here.

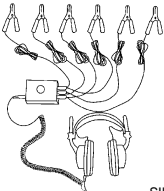
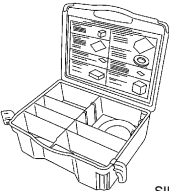
Tool number (Kent-Moore No.) Tool name	Description
<p>(J-39570) Chassis ear</p>  <p>SIIA0993E</p>	<p>Locates the noise</p>
<p>(J-43980) NISSAN Squeak and Rattle Kit</p>  <p>SIIA0994E</p>	<p>Repairs the cause of noise</p>

Commercial Service Tools

INFOID:000000006046564

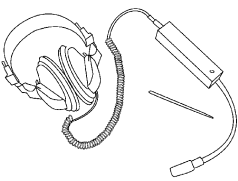
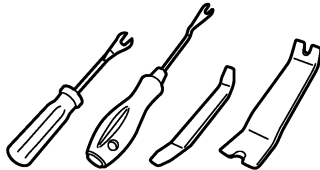
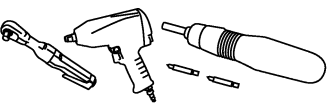
Tool name	Description
<p>Engine ear</p>  <p>SIIA0995E</p>	<p>Locates the noise</p>
<p>Remover tool</p>  <p>JMKIA3050ZZ</p>	<p>Removes the clips, pawls and metal clips</p>
<p>Power tool</p>  <p>PIIB1407E</p>	

CLIP LIST

< PREPARATION >

CLIP LIST

Clip List

INFOID:00000006046568

Shapes	Removal & Installation	Shapes	Removal & Installation
	<p>Removal: Remove by bending up with flat-bladed screwdrivers or clip remover.</p>		<p>Removal:</p>
	<p>Removal: Remove with a clip remover.</p>		<p>Removal:</p>
	<p>Removal: Push center pin to catching position. (Do not remove center pin by hitting it.)</p> <p>Installation:</p>		<p>Removal: Holder portion of clip must be spread out to remove rod.</p>
	<p>Removal: Remove by bending up with flat-bladed screwdrivers or clip remover.</p>		<p>Removal:</p> <ol style="list-style-type: none"> 1. Screw out with a Phillips screwdriver. 2. Remove female portion with flat-bladed screwdriver.
	<p>Removal:</p>		<p>Removal:</p> <p>Installation:</p>
	<p>Removal:</p>		<p>Removal:</p>

JMJIA3734GB

COMPONENT PARTS

< SYSTEM DESCRIPTION >

SYSTEM DESCRIPTION

COMPONENT PARTS

REAR SUNSHADE SYSTEM

REAR SUNSHADE SYSTEM : Component Parts Location

INFOID:000000006084412

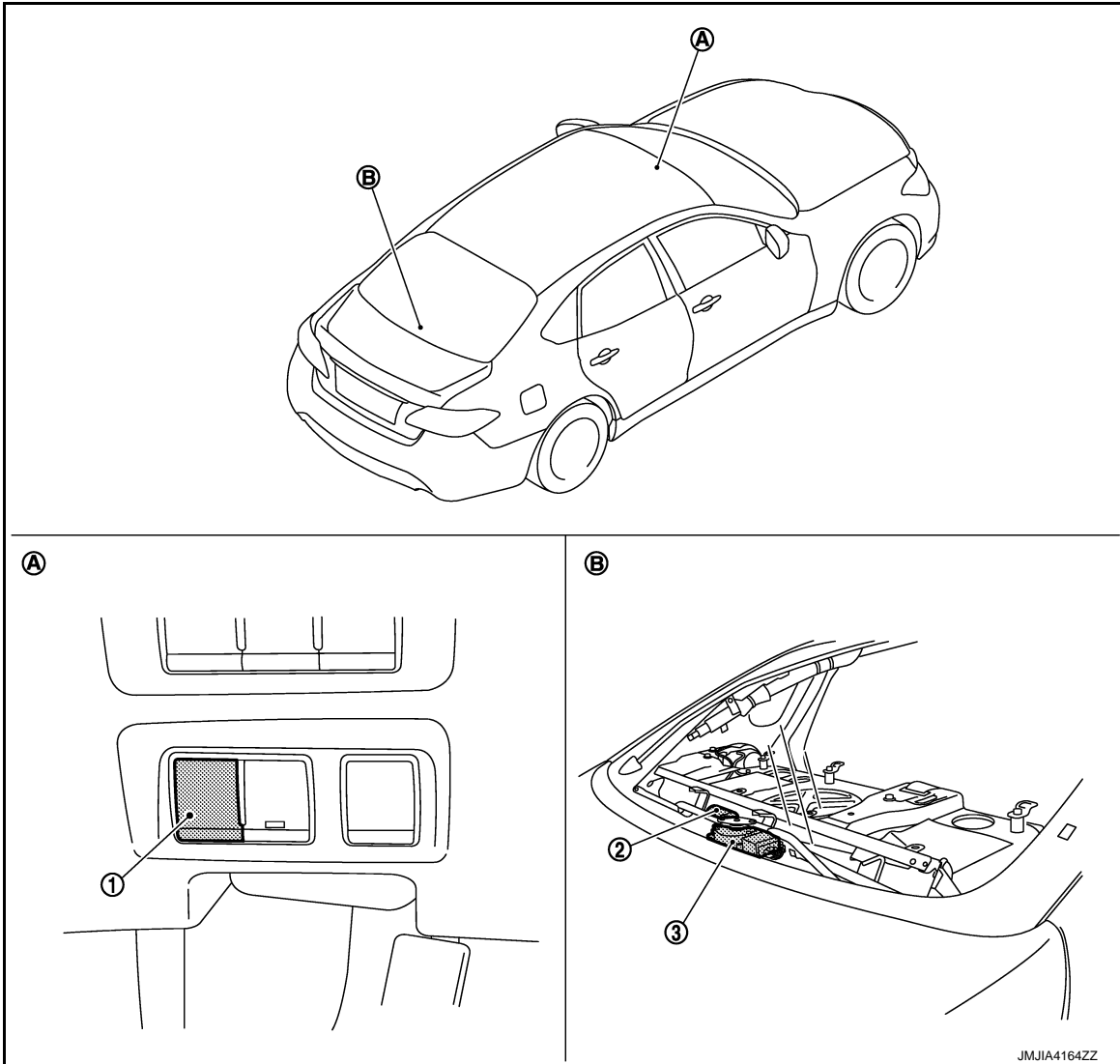

- 1. Rear sunshade switch
- 2. Rear sunshade motor
- 3. Rear sunshade control unit
- A. Left bottom side of instrument lower panel LH
- B. View with rear parcel shelf finisher removed

REAR SUNSHADE SYSTEM : Component Description

INFOID:000000006084413

Component parts		Description
Rear sunshade assembly	Rear sunshade control unit	<ul style="list-style-type: none"> • Rear sunshade control unit is installed to rear sunshade assembly. • Controls rear sunshade system by rear sunshade control unit.
	Rear sunshade motor	<ul style="list-style-type: none"> • Rear sunshade motor is installed to rear sunshade assembly. • Rear sunshade motor is activated with rear sunshade control unit.

A
B
C
D
E
F
G
H
I
INT
K
L
M
N
O
P

COMPONENT PARTS

< SYSTEM DESCRIPTION >

Component parts	Description
Rear sunshade switch	<ul style="list-style-type: none">• Rear sunshade switch is integrated in heated steering wheel switch (with heated steering wheel).• Operates rear sunshade motor and opens or closes rear sunshade, according to rear sunshade switch operation.
Back-up lamp relay	The reverse signal is transmitted to rear sunshade control unit.

SYSTEM

< SYSTEM DESCRIPTION >

SYSTEM

REAR SUNSHADE SYSTEM

REAR SUNSHADE SYSTEM : System Diagram

INFOID:000000006084414

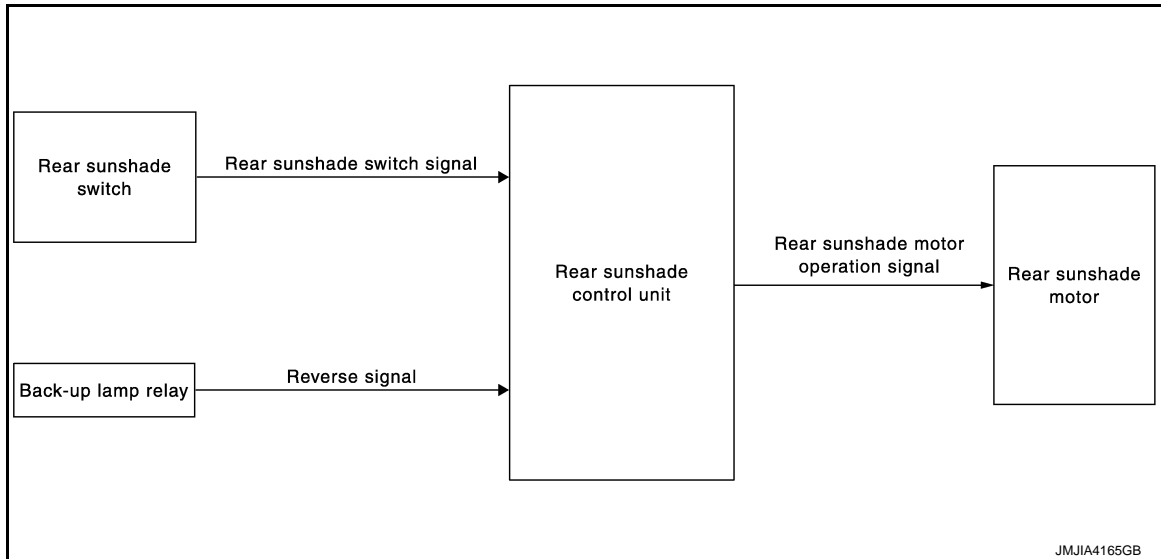

REAR SUNSHADE SYSTEM : System Description

INFOID:000000006084415

- Rear sunshade switch signal is transmitted to rear sunshade control unit when rear sunshade switch is operated.
- Rear sunshade control unit operates rear sunshade motor and opens or closes rear sunshade.
- Reverse signal is transmitted to rear sunshade control unit and rear sunshade is operated to the fully open position, when A/T shift selector is shifted to the R position while rear sunshade is in the closed position.
- When rear sunshade reaches fully open or closed position or its operation is interrupted by an obstacle, rear sunshade control unit detects overload of rear sunshade motor, interrupts power supply, and stops the operation.

REAR SUNSHADE CONTROL UNIT

< ECU DIAGNOSIS INFORMATION >

ECU DIAGNOSIS INFORMATION

REAR SUNSHADE CONTROL UNIT

Reference Value

INFOID:000000006084416

TERMINAL LAYOUT

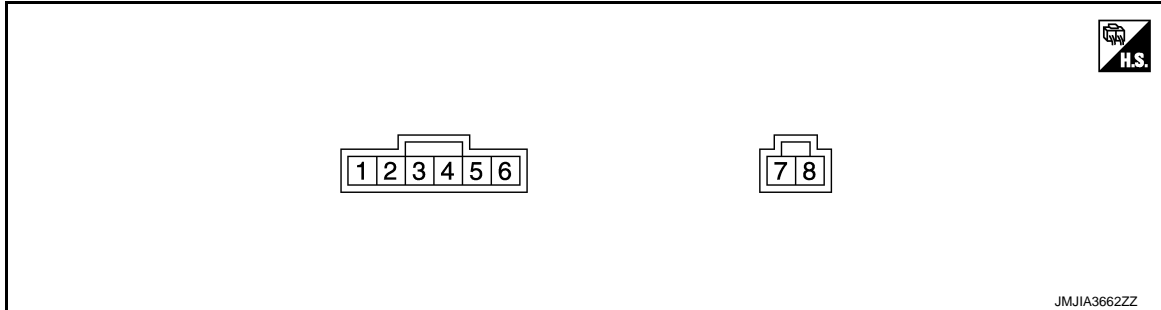

PHYSICAL VALUES

Terminal No. (Wire color)		Description		Condition		Voltage (V) (Approx.)
+	-	Signal name	Input/ Output			
1 (R/W)	Ground	Ignition power supply	Input	Ignition switch	ON	Battery voltage
					Other than the above	0
2 (BR)	Ground	Ground	—	—	—	0
4 (L)	Ground	Rear sunshade switch signal	Input	Rear sunshade switch	While being pressed	0
					Other than the above	12
6 (P)	Ground	Reverse signal	Input	A/T shift selector	R position	Battery voltage
					Other than the above	0
7 (W)	Ground	Rear sunshade open signal	Output	Rear sunshade	During rear sunshade operation (open)	12
					Other than the above	0
8 (G)	Ground	Rear sunshade close signal	Output	Rear sunshade	During rear sunshade operation (close)	12
					Other than the above	0

REAR SUNSHADE SYSTEM

< WIRING DIAGRAM >

WIRING DIAGRAM

REAR SUNSHADE SYSTEM

Wiring Diagram

INFOID:000000006084417

REAR SUNSHADE

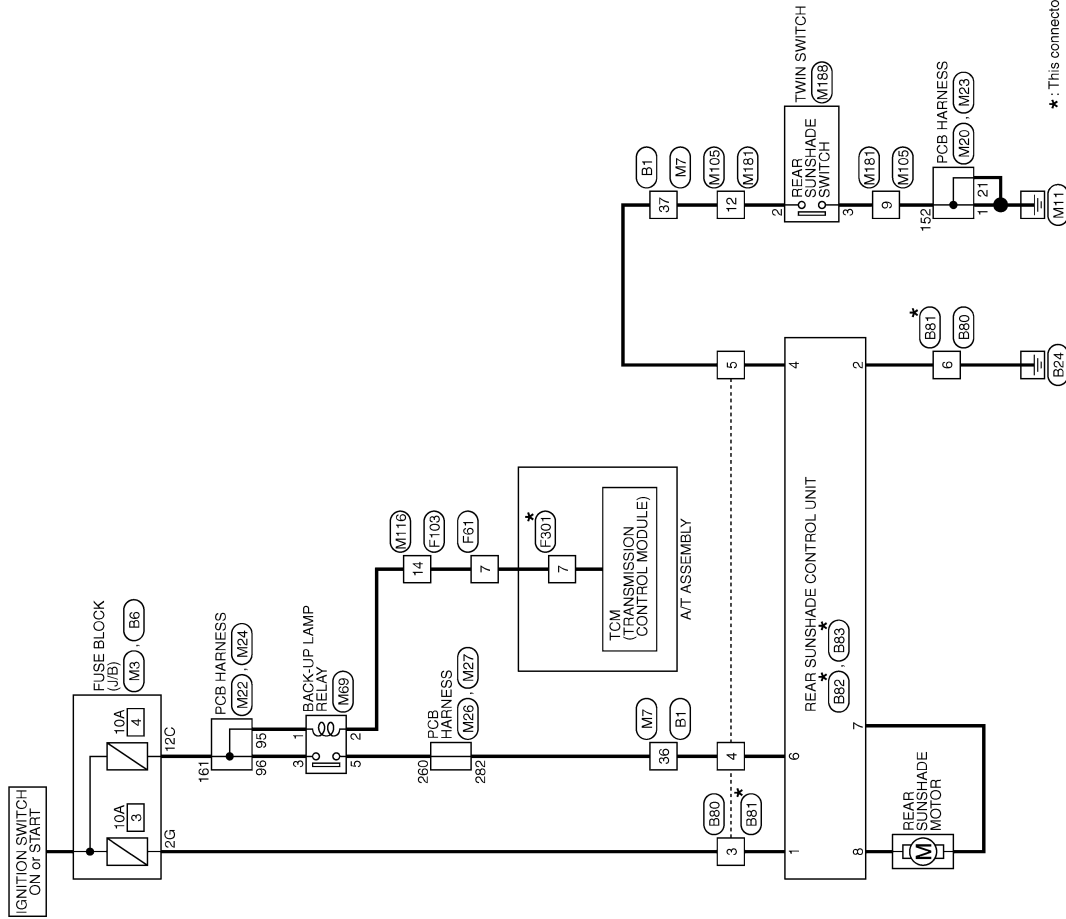

*: This connector is not shown in "Harness Layout".

2010/02/03

JCJWA1272GB

A
B
C
D
E
F
G
H
I
INT
K
L
M
N
O
P

REAR SUNSHADE SYSTEM

< WIRING DIAGRAM >

REAR SUNSHADE

Connector No.	B1
Connector Name	WIRE TO WIRE
Connector Type	TH08PW-CS16-TM4

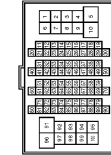

Terminal No.	Color of Wire	Signal Name [Specification]
1	R	-
2	W	-
4	LG	-
5	P	-
6	V	-
7	GR	-
8	Y	-
9	LG	-
10	V	-
11	GR	- [With Climate controlled seat]
12	P	- [With heated seat]
13	GR	- [With Climate controlled seat]
14	BR	- [With heated seat]
15	R	-
16	O	-
17	B	-
18	R	-
19	W	-
20	R	-
21	B	-
22	LG	-
23	V	-
24	Y	-
25	G	-
26	GR	-
27	SB	-
28	P	- [With Pre-crash seat belt system]
29	L/O	- [Without Pre-crash seat belt system]
29	L	- [With Pre-crash seat belt system]
29	W/L	- [Without Pre-crash seat belt system]
30	SHIELD	-
32	L	-
33	R	-
34	L	-
35	R	-
36	G	-

37	SB	-
40	SHIELD	-
41	GR/V	-
42	W/L	-
45	W	-
47	Y	-
48	V	-
49	BR	-
50	SB	-
51	V	-
52	LG	-
53	G	-
56	P	-
57	BR	-
58	LG	-
59	Y	-
60	W	-
61	B	-
62	LG	-
63	BR	- [With ICC and 4WAS system]
63	V	- [Without ICC and 4WAS system]
65	O	-
66	BR	-
67	V	-
68	LG	-
69	GR	-
70	R	-
72	L	-
73	P	-
74	L	-
75	P	-
76	Y	-
77	R	-
78	W	-
79	G	-
81	LG	-
82	BR	-
83	SB	-
84	Y	-
85	W	-
86	R	-
87	G	-
88	GR	-
91	SB	-
92	G	-
96	Y	-
97	O	-
98	SB	-
99	LG	-

Connector No.	B6
Connector Name	FUSE BLOCK (J/B)
Connector Type	NS12FBR-CS



Terminal No.	Color of Wire	Signal Name [Specification]
1G	GR	-
2G	P	-
4G	L	-
5G	P/L	- [With VK engine]
5G	P	- [With VQ engine]
6G	G	-
10G	W	-
11G	W	-
12G	V	-

Connector No.	B80
Connector Name	WIRE TO WIRE
Connector Type	TK08MF-TV

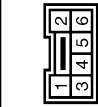

Terminal No.	Color of Wire	Signal Name [Specification]
3	P	-
4	G	-
5	SB	-
6	B/R	-

Connector No.	B81
Connector Name	WIRE TO WIRE
Connector Type	TK08WF-TV



Terminal No.	Color of Wire	Signal Name [Specification]
3	R/W	-
4	P	-
5	L	-
6	BR	-

Connector No.	B82
Connector Name	REAR SUNSHADE CONTROL UNIT
Connector Type	AMP 174823-1



Terminal No.	Color of Wire	Signal Name [Specification]
1	R/W	+IG
2	BR	GND
4	L	Switch (13.5V) : UP/DOWN
6	P	Reverse

REAR SUNSHADE SYSTEM

< WIRING DIAGRAM >

REAR SUNSHADE

Connector No.	B83
Connector Name	REAR SUNSHADE CONTROL UNIT
Connector Type	AMP 174462F-1



Terminal No.	Color of Wire	Signal Name [Specification]
7	W	-
8	G	-

Connector No.	F61
Connector Name	A/T ASSEMBLY
Connector Type	RK10FG-DGY

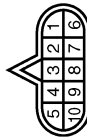

Terminal No.	Color of Wire	Signal Name [Specification]
1	Y	-
2	R	-
3	L	-
4	V	-
5	B	-
6	G	-
7	SB	-
8	P	-
9	LG	-
10	B	-

Connector No.	F103
Connector Name	WIRE TO WIRE
Connector Type	TK68FW-NS10



Terminal No.	Color of Wire	Signal Name [Specification]
2	L	-
3	G	-
4	B	- [With VK engine]
4	R	- [With VQ engine]
5	GR	- [With VK engine]
5	B	- [With VQ engine]
7	LG	-
8	Y	-
9	W	- [With VK engine]
9	SB	- [With VQ engine]
10	BR	- [With VK engine]
10	V	- [With VQ engine]
11	Y	-
12	L	-
13	V	-
14	SB	-
15	R	-
16	W	-
17	GR	-
18	LG	-
21	LG	-
22	B	-
23	G	-
24	BR	-
25	O	-

Connector No.	F801
Connector Name	TDM (TRANSMISSION CONTROL MODULE)
Connector Type	SP10FG

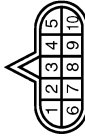

Terminal No.	Color of Wire	Signal Name [Specification]
1	W	VIGN
2	B	BATT
3	R	CAN-H
4	O	K LINE
5	G	GND
6	GR	VIGN
7	L	REV LAMP RLY
8	BR	CAN-L
9	Y	START RLY
10	W/B	GND

Connector No.	M8
Connector Name	FUSE BLOCK (J/B)
Connector Type	NS12FW-CS

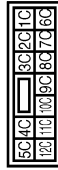

Terminal No.	Color of Wire	Signal Name [Specification]
6C	R	-
7C	B	-
9C	L	-
10C	LG	-
11C	LG	-
12C	6G	-

JCJWA1274GB

A
B
C
D
E
F
G
H
I
INT
K
L
M
N
O
P

REAR SUNSHADE SYSTEM

< WIRING DIAGRAM >

REAR SUNSHADE

Connector No.	M7
Connector Name	WIRE TO WIRE
Connector Type	TH80MW-CS16-TM4



Terminal No.	Color of Wire	Signal Name [Specification]
1	G	-
2	Y	-
4	BR	-
5	P	-
6	W	-
7	G	-
8	Y	-
9	G	-
10	V	-
11	L	- [With Climate controlled seat]
12	P	- [With heated seat]
13	GR	- [With Climate controlled seat]
14	BR	- [With heated seat]
15	GR	-
16	V	-
17	BG	- [With ICC]
18	B	- [Without ICC]
19	W	-
20	R	-
21	B	-
22	LG	-
23	W	-
24	V	-
25	G	-
26	BR	-
27	SB	-
28	P	-
29	L	-
30	SHIELD	-
32	L	-
33	P	-
34	L	-
35	P	-
36	BG	-
37	SB	-

40	SHIELD	-
41	SR	-
42	V	-
45	W	-
47	L	-
48	LG	-
49	BR	-
50	V	-
51	V	-
52	P	-
53	BG	-
56	SB	-
57	P	-
58	LG	-
59	Y	-
60	GR	-
61	B	-
62	LG	-
63	BR	-
65	W	-
66	R	-
67	V	-
68	LG	-
69	SB	-
70	V	-
72	L	-
73	P	-
74	L	-
75	P	-
76	G	-
77	Y	-
78	SB	-
79	W	-
81	LG	-
82	BR	-
83	BG	-
84	B	-
85	W	-
86	G	-
87	R	-
88	G	-
91	W	-
92	G	-
96	W	-
97	BG	-
98	Y	-
99	LG	-

Connector No.	M20
Connector Name	POB HARNESS
Connector Type	TH40FB-NH



Terminal No.	Color of Wire	Signal Name [Specification]
1	B	-
11	BR	-
12	R	-
14	L	-
15	B	-
17	R	-
19	W	-
20	R	-
21	B	-
22	R	-
23	L	-
24	L	-
27	P	-
30	SHIELD	-
31	V	-
33	V	-
35	L	-
36	P	-
38	L	-
40	Y	-

Connector No.	M22
Connector Name	POB HARNESS
Connector Type	TH40FB-NH



Terminal No.	Color of Wire	Signal Name [Specification]
81	L	-
82	P	-

83	B	-
84	B	-
85	B	-
86	B	-
87	B	-
88	B	-
89	Y	-
91	V	-
92	V	-
93	B	-
94	B	-
95	LG	-
96	BR	-
97	G	-
98	G	-
99	G	-
100	G	-
101	L	-
102	P	-
103	B	-
104	BR	-
105	R	-
107	Y	-
108	Y	-
109	BR	-
110	Y	-
112	B	-
113	P	-
114	L	-
116	B	-
117	BG	- [With VK engines]
118	B	- [With VQ engines]
119	G	-
120	V	-

REAR SUNSHADE SYSTEM

< WIRING DIAGRAM >

REAR SUNSHADE

Connector No.	M23
Connector Name	POB HARNESS
Connector Type	TH40FW-NH



1	2	3	4	5	6	7	8	9	10	11	12	13	14	15	16	17	18	19	20	21	22	23	24	25	26	27	28	29	30	31	32	33	34	35	36	37	38	39	40	41	42	43	44	45	46	47	48	49	50	51	52	53	54	55	56	57	58	59	60	61	62	63	64	65	66	67	68	69	70	71	72	73	74	75	76	77	78	79	80	81	82	83	84	85	86	87	88	89	90	91	92	93	94	95	96	97	98	99	100
---	---	---	---	---	---	---	---	---	----	----	----	----	----	----	----	----	----	----	----	----	----	----	----	----	----	----	----	----	----	----	----	----	----	----	----	----	----	----	----	----	----	----	----	----	----	----	----	----	----	----	----	----	----	----	----	----	----	----	----	----	----	----	----	----	----	----	----	----	----	----	----	----	----	----	----	----	----	----	----	----	----	----	----	----	----	----	----	----	----	----	----	----	----	----	----	----	----	----	-----



Connector No.	M24
Connector Name	POB HARNESS
Connector Type	TH40FW-NH



101	102	103	104	105	106	107	108	109	110	111	112	113	114	115	116	117	118	119	120	121	122	123	124	125	126	127	128	129	130	131	132	133	134	135	136	137	138	139	140	141	142	143	144	145	146	147	148	149	150	151	152	153	154	155	156	157	158	159	160	161	162	163	164	165	166	167	168	169	170	171	172	173	174	175	176	177	178	179	180	181	182	183	184	185	186	187	188	189	190	191	192	193	194	195	196	197	198	199	200
-----	-----	-----	-----	-----	-----	-----	-----	-----	-----	-----	-----	-----	-----	-----	-----	-----	-----	-----	-----	-----	-----	-----	-----	-----	-----	-----	-----	-----	-----	-----	-----	-----	-----	-----	-----	-----	-----	-----	-----	-----	-----	-----	-----	-----	-----	-----	-----	-----	-----	-----	-----	-----	-----	-----	-----	-----	-----	-----	-----	-----	-----	-----	-----	-----	-----	-----	-----	-----	-----	-----	-----	-----	-----	-----	-----	-----	-----	-----	-----	-----	-----	-----	-----	-----	-----	-----	-----	-----	-----	-----	-----	-----	-----	-----	-----	-----	-----	-----	-----



Connector No.	M26
Connector Name	POB HARNESS
Connector Type	TH40FW-NH



201	202	203	204	205	206	207	208	209	210	211	212	213	214	215	216	217	218	219	220	221	222	223	224	225	226	227	228	229	230	231	232	233	234	235	236	237	238	239	240	241	242	243	244	245	246	247	248	249	250	251	252	253	254	255	256	257	258	259	260	261	262	263	264	265	266	267	268	269	270	271	272	273	274	275	276	277	278	279	280	281	282	283	284	285	286	287	288	289	290	291	292	293	294	295	296	297	298	299	300	301	302	303	304	305	306	307	308	309	310	311	312	313	314	315	316	317	318	319	320	321	322	323	324	325	326	327	328	329	330	331	332	333	334	335	336	337	338	339	340	341	342	343	344	345	346	347	348	349	350	351	352	353	354	355	356	357	358	359	360	361	362	363	364	365	366	367	368	369	370	371	372	373	374	375	376	377	378	379	380	381	382	383	384	385	386	387	388	389	390	391	392	393	394	395	396	397	398	399	400
-----	-----	-----	-----	-----	-----	-----	-----	-----	-----	-----	-----	-----	-----	-----	-----	-----	-----	-----	-----	-----	-----	-----	-----	-----	-----	-----	-----	-----	-----	-----	-----	-----	-----	-----	-----	-----	-----	-----	-----	-----	-----	-----	-----	-----	-----	-----	-----	-----	-----	-----	-----	-----	-----	-----	-----	-----	-----	-----	-----	-----	-----	-----	-----	-----	-----	-----	-----	-----	-----	-----	-----	-----	-----	-----	-----	-----	-----	-----	-----	-----	-----	-----	-----	-----	-----	-----	-----	-----	-----	-----	-----	-----	-----	-----	-----	-----	-----	-----	-----	-----	-----	-----	-----	-----	-----	-----	-----	-----	-----	-----	-----	-----	-----	-----	-----	-----	-----	-----	-----	-----	-----	-----	-----	-----	-----	-----	-----	-----	-----	-----	-----	-----	-----	-----	-----	-----	-----	-----	-----	-----	-----	-----	-----	-----	-----	-----	-----	-----	-----	-----	-----	-----	-----	-----	-----	-----	-----	-----	-----	-----	-----	-----	-----	-----	-----	-----	-----	-----	-----	-----	-----	-----	-----	-----	-----	-----	-----	-----	-----	-----	-----	-----	-----	-----	-----	-----	-----	-----	-----	-----	-----	-----	-----	-----	-----	-----	-----	-----	-----



Connector No.	M27
Connector Name	POB HARNESS
Connector Type	TH40FB-NH



401	402	403	404	405	406	407	408	409	410	411	412	413	414	415	416	417	418	419	420	421	422	423	424	425	426	427	428	429	430	431	432	433	434	435	436	437	438	439	440	441	442	443	444	445	446	447	448	449	450	451	452	453	454	455	456	457	458	459	460	461	462	463	464	465	466	467	468	469	470	471	472	473	474	475	476	477	478	479	480	481	482	483	484	485	486	487	488	489	490	491	492	493	494	495	496	497	498	499	500
-----	-----	-----	-----	-----	-----	-----	-----	-----	-----	-----	-----	-----	-----	-----	-----	-----	-----	-----	-----	-----	-----	-----	-----	-----	-----	-----	-----	-----	-----	-----	-----	-----	-----	-----	-----	-----	-----	-----	-----	-----	-----	-----	-----	-----	-----	-----	-----	-----	-----	-----	-----	-----	-----	-----	-----	-----	-----	-----	-----	-----	-----	-----	-----	-----	-----	-----	-----	-----	-----	-----	-----	-----	-----	-----	-----	-----	-----	-----	-----	-----	-----	-----	-----	-----	-----	-----	-----	-----	-----	-----	-----	-----	-----	-----	-----	-----	-----	-----	-----



Terminal No.	Color of Wire	Signal Name [Specification]
121	R	-
122	V	-
123	BG	-
124	BG	-
128	BR	-
130	B	-
131	SB	-
132	LG	-
133	L	-
135	P	-
137	Y	-
138	L	-
139	P	-
140	L	-
141	W	-
142	W	-
144	P	-
145	R	-
146	LG	-
147	B	-
148	L	-
149	B	-
150	P	-
151	L	-
152	B	-
153	W	-
154	W	-
155	W	-
157	W	-
158	R	-
159	R	-

Terminal No.	Color of Wire	Signal Name [Specification]
161	BG	-
162	BG	-
163	G	-
164	V	-
165	V	-
166	R	-
167	LG	-
168	R	-
169	R	-
170	B	-
172	B	-
174	W	-
175	B	-
176	L	-
177	P	-
178	Y	-
179	L	-
180	LG	-
182	BR	-
183	G	-
184	V	-
185	P	-
185	V	- [With BOSE system]
185	V	- [Without BOSE system]
186	R	-
187	L	-
188	Y	-
189	B	-
190	V	-
191	G	-
192	B	-
193	SB	-
194	BR	-
198	R	-
199	B	-
200	SB	-

Terminal No.	Color of Wire	Signal Name [Specification]
241	L	-
243	R	-
244	L	-
245	B	-
246	B	-
247	LG	- [With Climate controlled seat]
247	B	- [With heated seat]
249	SHIELD	-
250	SHIELD	-
253	P	- [With Climate controlled seat]
253	B	- [With heated seat]
254	W	- [With Climate controlled seat]
254	B	- [With heated seat]
255	B	-
256	SHIELD	-
257	SHIELD	-
258	R	-
259	L	-
260	EG	-
261	P	-
269	GR	-
270	Y	-
271	BR	-
272	G	-
273	R	-
274	R	-
275	Y	-
276	B	-
277	G	-
278	R	-
279	SB	-
279	R	- [With Climate controlled seat]
280	Y	- [With heated seat]

Terminal No.	Color of Wire	Signal Name [Specification]
282	BG	-
283	BG	-
284	LG	-
286	W	-
287	Y	-
288	W	-
290	B	-
292	B	-
293	B	-
294	B	-
295	B	-
299	V	-
301	R	-
302	R	-
303	R	-
319	V	-
320	W	-

Connector No.	M69
Connector Name	BACK-UP LAMP RELAY
Connector Type	MSD0FL-M2-LC



Terminal No.	Color of Wire	Signal Name [Specification]
1	LG	-
2	R	-
3	BR	-
5	BG	-

JCJWA1276GB

A
B
C
D
E
F
G
H
I
INT
K
L
M
N
O
P

REAR SUNSHADE SYSTEM

< WIRING DIAGRAM >

REAR SUNSHADE

Connector No.	M105
Connector Name	WIRE TO WIRE
Connector Type	TH40PW-NH

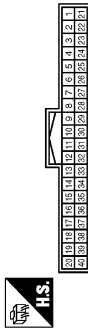

Connector No.	M116
Connector Name	WIRE TO WIRE
Connector Type	TK68MW-NS10



Terminal No.	Color of Wire	Signal Name [Specification]
2	R	-
3	B	-
4	B	-
5	B	-
6	BR	-
7	L	-
8	P	-
9	B	-
10	W	-
11	LG	-
12	SB	-
14	SB	-
15	BR	-
16	V	-
18	G	-
19	B	-
20	V	-
22	BG	-
23	B	-
25	W	-
30	R	-
31	BR	-
32	L	-
33	P	-
34	LG	-
35	W	-
36	LG	-
37	L	-
38	R	-

Connector No.	M188
Connector Name	TWIN SWITCH
Connector Type	TH12FGY-NH

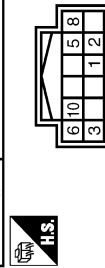

Terminal No.	Color of Wire	Signal Name [Specification]
1	G	-
2	SB	-
3	B	-
5	BG	-
6	B	-
8	W	-

Terminal No.	Color of Wire	Signal Name [Specification]
2	R	-
3	B	-
5	LG	-
6	P	-
7	L	-
8	P	-
9	B	-
10	W	-
11	W	-
12	SB	-
14	SB	-
15	BR	-
16	V	-
18	G	-
19	B	-
20	V	-
22	BG	-
23	B	-
25	W	-
30	R	-
31	BR	-
32	L	-
33	P	-
34	LG	-
35	W	-
36	LG	-
37	L	-
38	R	-

Connector No.	M181
Connector Name	WIRE TO WIRE
Connector Type	TH40MW-NH



JCJWA1277GB

DIAGNOSIS AND REPAIR WORK FLOW

< BASIC INSPECTION >

BASIC INSPECTION

DIAGNOSIS AND REPAIR WORK FLOW

WorkFlow

INFOID:000000006103016

DETAILED FLOW

1.OBTAIN INFORMATION ABOUT SYMPTOM

Interview the customer to obtain as much malfunction information (conditions and environment when the malfunction occurred) as possible when the customer brings the vehicle in.

>> GO TO 2.

2.REPRODUCE THE MALFUNCTION INFORMATION

Check the malfunction on the vehicle that the customer describes.
Inspect the relation of the symptoms and the condition when the symptoms occur.

>> GO TO 3.

3.IDENTIFY THE MALFUNCTIONING SYSTEM WITH "SYMPTOM DIAGNOSIS"

Use "Symptom Diagnosis" from the symptom inspection result in step 2 and then identify where to start performing the diagnosis based on possible causes and symptoms.

>> GO TO 4.

4.IDENTIFY THE MALFUNCTIONING PARTS WITH "COMPONENT DIAGNOSIS"

Perform the diagnosis with "Component Diagnosis" of the applicable system.

>> GO TO 5.

5.REPAIR OR REPLACE THE MALFUNCTIONING PARTS

Repair or replace the specified malfunctioning parts.

>> GO TO 6.

6.FINAL CHECK

Check that malfunctions are not reproduced when obtaining the malfunction information from the customer, referring to the symptom inspection result in step 2.

Are the malfunctions corrected?

YES >> INSPECTION END

NO >> GO TO 3.

A
B
C
D
E
F
G
H
I
INT
K
L
M
N
O
P

POWER SUPPLY AND GROUND CIRCUIT

< DTC/CIRCUIT DIAGNOSIS >

DTC/CIRCUIT DIAGNOSIS

POWER SUPPLY AND GROUND CIRCUIT REAR SUNSHADE CONTROL UNIT

REAR SUNSHADE CONTROL UNIT : Diagnosis Procedure

INFOID:000000006084419

1. CHECK FUSE

Check that the following fuse and fusible link are not fusing.

Signal name	Fuse No.
Ignition power supply	3 (10 A)

Is the inspection result normal?

YES >> GO TO 2.

NO >> Replace the blown fuse after repairing the affected circuit.

2. CHECK REAR SUNSHADE CONTROL UNIT POWER SUPPLY

1. Turn ignition switch OFF.
2. Disconnect rear sunshade control unit connector.
3. Turn ignition switch ON.
4. Check voltage between rear sunshade control unit harness connector and ground.

(+)		(-)	Condition	Voltage (V) (Approx.)
Connector	Terminal			
B82	1	Ground	Ignition switch	ON Battery voltage
			OFF 0	

Is the inspection result normal?

YES >> GO TO 3.

NO >> Repair or replace harness.

3. CHECK REAR SUNSHADE CONTROL UNIT GROUND CIRCUIT

1. Turn ignition switch OFF.
2. Check continuity between rear sunshade control unit harness connector and ground.

Rear sunshade control unit		Ground	Continuity
Connector	Terminal		
B82	2		Existed

Is the inspection result normal?

YES >> INSPECTION END

NO >> Replace or repair harness.

REAR SUNSHADE SWITCH

< DTC/CIRCUIT DIAGNOSIS >

REAR SUNSHADE SWITCH

Component Function Check

INFOID:000000006084420

1.CHECK REAR SUNSHADE SWITCH FUNCTION

Operate rear sunshade switch and check rear sunshade operation.

Is the inspection result normal?

- YES >> INSPECTION END
- NO >> Refer to [INT-19, "Diagnosis Procedure"](#).

Diagnosis Procedure

INFOID:000000006084421

1.CHECK REAR SUNSHADE SWITCH POWER SUPPLY

1. Turn ignition switch OFF.
2. Disconnect twin switch connector.
3. Turn ignition switch ON.
4. Check voltage between twin switch harness connector and ground.

(+)		(-)	Voltage (V) (Approx.)
Twin switch			
Connector	Terminal		
M188	2	Ground	12

Is the inspection result normal?

- YES >> GO TO 3.
- NO >> GO TO 2.

2.CHECK REAR SUNSHADE SWITCH POWER SUPPLY CIRCUIT

1. Turn ignition switch OFF.
2. Disconnect rear sunshade control unit connector.
3. Check continuity between rear sunshade control unit harness connector and twin switch harness connector.

Rear sunshade control unit		Twin switch		Continuity
Connector	Terminal	Connector	Terminal	
B82	4	M188	2	Existed

4. Check continuity between rear sunshade control unit harness connector and ground.

Rear sunshade control unit		Ground	Continuity
Connector	Terminal		
B82	4		Not existed

Is the inspection result normal?

- YES >> Replace rear sunshade assembly.
- NO >> Repair or replace harness.

3.CHECK REAR SUNSHADE SWITCH GROUND CIRCUIT

1. Turn ignition switch OFF.
2. Check continuity between twin switch harness connector and ground.

Twin switch		Ground	Continuity
Connector	Terminal		
M188	3		Existed

Is the inspection result normal?

- YES >> GO TO 4.

REAR SUNSHADE SWITCH

< DTC/CIRCUIT DIAGNOSIS >

NO >> Repair or replace harness.

4.CHECK REAR SUNSHADE SWITCH

Check rear sunshade switch.

Refer to [INT-20. "Component Inspection"](#).

Is the inspection result normal?

YES >> GO TO 5.

NO >> Replace rear sunshade switch.

5.CHECK INTERMITTENT INCIDENT

Refer to [GI-38. "Intermittent Incident"](#).

>> INSPECTION END

Component Inspection

INFOID:000000006084422

1..CHECK REAR SUNSHADE SWITCH

1. Turn ignition switch OFF.
2. Disconnect twin switch connector.
3. Check continuity between twin switch terminals under the following conditions.

Twin switch		Condition	Continuity	
Terminal				
2	3	Rear sunshade switch	While being pressed	Existed
			Release	Not existed

Is the inspection result normal?

YES >> INSPECTION END

NO >> Replace rear sunshade switch.

REVERSE SIGNAL CIRCUIT

< DTC/CIRCUIT DIAGNOSIS >

REVERSE SIGNAL CIRCUIT

Component Function Check

INFOID:000000006084426

1.CHECK BACK-UP LAMP RELAY FUNCTION

Check that rear sunshade returns to the fully open position when shifting A/T shift selector to the R position while rear sunshade is in the fully closed position.

Is the inspection result normal?

- YES >> INSPECTION END
NO >> Refer to [INT-21. "Diagnosis Procedure"](#)

Diagnosis Procedure

INFOID:000000006084427

1.CHECK REVERSE SIGNAL

1. Turn ignition switch OFF.
2. Disconnect rear sunshade control unit connector.
3. Turn ignition switch ON.
4. Shift A/T shift selector to R position.
5. Check voltage between rear sunshade control unit harness connector and ground.

(+)		(-)	Condition	Voltage (V) (Approx.)	
Connector	Terminal				
B82	6	Ground	A/T shift selector	R position	Battery voltage
				Other than the above	0

Is the inspection result normal?

- YES >> Replace rear sunshade assembly.
NO >> Check back-up lamp circuit. Refer to [EXL-42. "EXTERIOR LIGHTING SYSTEM : Wiring Diagram"](#).

A
B
C
D
E
F
G
H
I
K
L
M
N
O
P

INT

REAR SUNSHADE DOES NOT OPERATE

< SYMPTOM DIAGNOSIS >

SYMPTOM DIAGNOSIS

REAR SUNSHADE DOES NOT OPERATE

Diagnosis Procedure

INFOID:000000006084389

1. CHECK REAR SUNSHADE CONTROL UNIT POWER SUPPLY AND GROUND CIRCUIT

Check rear sunshade control unit power supply and ground circuit.

Refer to [INT-18. "REAR SUNSHADE CONTROL UNIT : Diagnosis Procedure"](#).

Is the inspection result normal?

YES >> GO TO 2.

NO >> Repair or replace the malfunction parts.

2. CHECK REAR SUNSHADE SWITCH

Check rear sunshade switch.

Refer to [INT-19. "Component Function Check"](#).

Is the inspection result normal?

YES >> GO TO 3.

NO >> Repair or replace the malfunction parts.

3. CONFIRM THE OPERATION

Check the operation again.

Is the result normal?

YES >> Check intermittent incident. Refer to [GI-38. "Intermittent Incident"](#).

NO >> GO TO 1.

REAR SUNSHADE DOES NOT OPEN WHEN SELECTOR LEVER IS SHIFTED TO THE "R" POSITION

< SYMPTOM DIAGNOSIS >

REAR SUNSHADE DOES NOT OPEN WHEN SELECTOR LEVER IS SHIFTED TO THE "R" POSITION

Diagnosis Procedure

INFOID:000000006084392

1. CHECK BACK-UP LAMP RELAY FUNCTION

Check back-up lamp relay function.

Refer to [INT-21, "Component Function Check"](#).

Is the inspection result normal?

YES >> GO TO 2.

NO >> Repair or replace the malfunction parts.

2. CONFIRM THE OPERATION

Check the operation again.

Is the result normal?

YES >> Check intermittent incident. Refer to [GI-38, "Intermittent Incident"](#).

NO >> GO TO 1.

A
B
C
D
E
F
G
H
I
K
L
M
N
O
P

INT

SQUEAK AND RATTLE TROUBLE DIAGNOSES

< SYMPTOM DIAGNOSIS >

SQUEAK AND RATTLE TROUBLE DIAGNOSES

Work Flow

INFOID:000000006059726

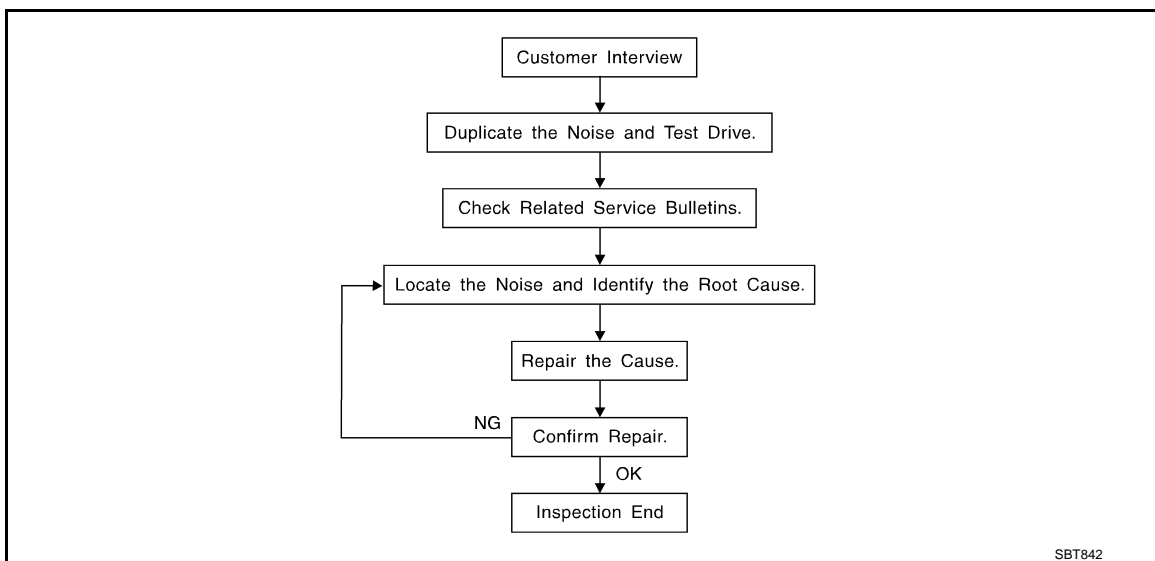

CUSTOMER INTERVIEW

Interview the customer if possible, to determine the conditions that exist when the noise occurs. Use the Diagnostic Worksheet during the interview to document the facts and conditions when the noise occurs and any customer comments. Refer to [INT-28, "Diagnostic Worksheet"](#). This information is necessary to duplicate the conditions that exist when the noise occurs.

- The customer may not be able to provide a detailed description or the location of the noise. Attempt to obtain all the facts and conditions that exist when the noise occurs (or does not occur).
- If there is more than one noise in the vehicle, perform a diagnosis and repair the noise that the customer is concerned about. This can be accomplished by performing a test drive with the customer.
- After identifying the type of noise, isolate the noise in terms of its characteristics. The noise characteristics are provided so that the customer, service adviser, and technician use the same language when describing the noise.
- Squeak – (Like tennis shoes on a clean floor)
Squeak characteristics include the light contact / fast movement / brought on by road conditions / hard surfaces = high-pitched noise / softer surfaces = low-pitched noises / edge to surface = chirping
- Creak – (Like walking on an old wooden floor)
Creak characteristics include firm contact / slow movement/twisting with a rotational movement / pitch dependent on materials / often brought on by activity.
- Rattle – (Like shaking a baby rattle)
Rattle characteristics include fast repeated contact / vibration or similar movement / loose parts/missing clip or fastener / incorrect clearance.
- Knock – (Like a knock on a door)
Knock characteristics include hollow sounds / sometimes repeating / often brought on by driver action.
- Tick – (Like a clock second hand)
Tick characteristics include gentle contacting of light materials / loose components / can be caused by driver action or road conditions.
- Thump – (Heavy, muffled knock noise)
Thump characteristics include softer knock / dull sounds often brought on by activity.
- Buzz – (Like a bumblebee)
Buzz characteristics include high frequency rattle / firm contact.
- Often the degree of acceptable noise level varies depending upon the person. A noise that a technician may judge as acceptable may be very irritating to a customer.
- Weather conditions, especially humidity and temperature, may have a great effect on noise level.

DUPLICATE THE NOISE AND TEST DRIVE

If possible, drive the vehicle with the customer until the noise is duplicated. Note any additional information on the Diagnostic Worksheet regarding the conditions or location of the noise. This information can be used to duplicate the same conditions when the repair is reconfirmed.

SQUEAK AND RATTLE TROUBLE DIAGNOSES

< SYMPTOM DIAGNOSIS >

If the noise can be duplicated easily during the test drive, to help identify the source of the noise, try to duplicate the noise with the vehicle stopped by doing one or all of the following items:

- 1) Close a door.
 - 2) Tap or push/pull around the area where the noise appears to be coming from.
 - 3) Rev the engine.
 - 4) Use a floor jack to recreate vehicle "twist".
 - 5) At idle, apply engine load (electrical load, half-clutch on M/T models, drive position on A/T models).
 - 6) Raise the vehicle on a hoist and hit a tire with a rubber hammer.
- Drive the vehicle and attempt to duplicate the conditions the customer states exist when the noise occurs.
 - If it is difficult to duplicate the noise, drive the vehicle slowly on an undulating or rough road to stress the vehicle body.

CHECK RELATED SERVICE BULLETINS

After verifying the customer concern or symptom, check ASIST for Technical Service Bulletins (TSBs) related to the concern or symptom.

If a TSB relates to the symptom, follow the procedure to repair the noise.

LOCATE THE NOISE AND IDENTIFY THE ROOT CAUSE

1. Narrow down the noise to a general area. To help pinpoint the source of the noise, use a listening tool (Chassis ear: J-39570, engine ear, and mechanics stethoscope).
2. Narrow down the noise to a more specific area and identify the cause of the noise by:
 - Removing the component(s) in the area that is / are suspected to be the cause of the noise. Do not use too much force when removing clips and fasteners, otherwise clips and fasteners can be broken or lost during the repair, resulting in the creation of new noise.
 - Tapping or pushing/pulling the component(s) that is / are suspected to be the cause of the noise. Do not tap or push/pull the component(s) with excessive force, otherwise the noise is eliminated only temporarily.
 - Feeling for a vibration by hand by touching the component(s) that is / are suspected to be the cause of the noise.
 - Placing a piece of paper between components that are suspected to be the cause of the noise.
 - Looking for loose components and contact marks.
Refer to [INT-26. "Inspection Procedure"](#).

REPAIR THE CAUSE

- If the cause is a loose component, tighten the component securely.
- If the cause is insufficient clearance between components:
 - Separate components by repositioning or loosening and retightening the components, if possible.
 - Insulate components with a suitable insulator such as urethane pads, foam blocks, felt cloth tape, or urethane tape. A NISSAN Squeak and Rattle Kit (J-43980) is available through the authorized NISSAN Parts Department.

CAUTION:

Never use excessive force as many components are constructed of plastic and may be damaged.

NOTE:

Always check with the Parts Department for the latest parts information.

The following materials are contained in the NISSAN Squeak and Rattle Kit (J-43980). Each item can be ordered separately as needed.

URETHANE PADS [1.5 mm (0.059 in) thick]

Insulates connectors, harness, etc.

- 76268-9E005: 100 × 135 mm (3.937 × 5.315 in)
- 76884-71L01: 60 × 85 mm (2.362 × 3.346 in)
- 76884-71L02: 15 × 25 mm (0.591 × 0.984 in)

INSULATOR (Foam blocks)

Insulates components from contact. Can be used to fill space behind a panel.

- 73982-9E000: 45 mm (1.772 in) thick, 50 × 50 mm (1.969 × 1.969 in)
- 73982-50Y00: 10 mm (0.394 in) thick, 50 × 50 mm (1.969 × 1.969 in)

INSULATOR (Light foam block)

80845-71L00: 30 mm (1.181 in) thick, 30 × 50 mm (1.181 × 1.969 in)

FELT CLOTH TAPE

Used to insulate where movement does not occur. Ideal for instrument panel applications.

- 68370-4B000: 15 × 25 mm (0.591 × 0.984 in) pad
- 68239-13E00: 5 mm (0.197 in) wide tape roll

SQUEAK AND RATTLE TROUBLE DIAGNOSES

< SYMPTOM DIAGNOSIS >

The following materials, not found in the kit, can also be used to repair squeaks and rattles.

UHMW (TEFLON) TAPE

Insulates where slight movement is present. Ideal for instrument panel applications.

SILICONE GREASE

Used in place of UHMW tape that is visible or does not fit. Only lasts a few months.

SILICONE SPRAY

Used when grease cannot be applied.

DUCT TAPE

Used to eliminate movement.

CONFIRM THE REPAIR

After repair is complete, test drive the vehicle to confirm that the cause of noise is repaired by test driving the vehicle. Operate the vehicle under the same conditions as when the noise originally occurred. Refer to the notes on the Diagnostic Worksheet.

Inspection Procedure

INFOID:000000006059727

Refer to Table of Contents for specific component removal and installation information.

INSTRUMENT PANEL

Most incidents are caused by contact and movement between:

1. The cluster lid A and instrument panel
2. Acrylic lens and combination meter housing
3. Instrument panel to front pillar garnish
4. Instrument panel to windshield
5. Instrument panel mounting pins
6. Wiring harnesses behind the combination meter
7. A/C defroster duct and duct joint

These incidents can usually be located by tapping or moving the components to duplicate the noise or by pressing on the components while driving to stop the noise. Most of these incidents can be repaired by applying felt cloth tape or silicon spray (in hard to reach areas). Urethane pads can be used to insulate wiring harness.

CAUTION:

Never use silicone spray to isolate a squeak or rattle. If the area is saturated with silicone, the recheck of repair becomes impossible.

CENTER CONSOLE

Components to check include:

1. Shifter assembly cover to finisher
2. A/C control unit and cluster lid C
3. Wiring harnesses behind audio and A/C control unit

The instrument panel repair and isolation procedures also apply to the center console.

DOORS

Check the following items:

1. Finisher and inner panel making a slapping noise
2. Inside handle escutcheon connection to door finisher
3. Wiring harnesses tapping
4. Door striker out of alignment causing a popping noise on starts and stops

Tapping, moving the components, or pressing on them while driving to duplicate the conditions can isolate many of these incidents. The areas can usually be insulated with felt cloth tape or insulator foam blocks from the NISSAN Squeak and Rattle Kit (J-43980) to repair the noise.

TRUNK

Trunk noises are often caused by a loose jack or loose items put into the trunk by the customer.

In addition check for the following items:

1. Trunk lid dumpers out of adjustment
2. Trunk lid striker out of adjustment

SQUEAK AND RATTLE TROUBLE DIAGNOSES

< SYMPTOM DIAGNOSIS >

3. Trunk lid torsion bars knocking together
4. A loose license plate or bracket

Most of these incidents can be repaired by adjusting, securing, or insulating the item(s) or component(s) causing the noise.

SUNROOF/HEADLINING

Noises in the sunroof / headlining area can often be traced to one of the following items:

1. Sunroof lid, rail, linkage, or seals making a rattle or light knocking noise
2. Sunvisor shaft shaking in the holder
3. Front or rear windshield touching headlining and squeaking

Again, pressing on the components to stop the noise while duplicating the conditions can isolate most of these incidents. Repairs usually consist of insulating with felt cloth tape.

SEATS

When isolating seat noise it is important to note the position the seat is in and the load placed on the seat when the noise occurs. These conditions should be duplicated when verifying and isolating the cause of the noise.

Causes of seat noise include:

1. Headrest rods and holder
2. A squeak between the seat pad cushion and frame
3. The rear seatback lock and bracket

These noises can be isolated by moving or pressing on the suspected components while duplicating the conditions under which the noise occurs. Most of these incidents can be repaired by repositioning the component or applying urethane tape to the contact area.

UNDERHOOD

Some interior noise may be caused by components under the hood or on the engine wall. The noise is then transmitted into the passenger compartment.

Causes of transmitted underhood noise include:

1. Any component mounted to the engine wall
2. Components that pass through the engine wall
3. Engine wall mounts and connectors
4. Loose radiator mounting pins
5. Hood bumpers out of adjustment
6. Hood striker out of adjustment

These noises can be difficult to isolate since they cannot be reached from the interior of the vehicle. The best method is to secure, move, or insulate one component at a time and test drive the vehicle. Also, engine RPM or load can be changed to isolate the noise. Repairs can usually be made by moving, adjusting, securing, or insulating the component causing the noise.

A
B
C
D
E
F
G
H
I
K
L
M
N
O
P

INT

SQUEAK AND RATTLE TROUBLE DIAGNOSES

< SYMPTOM DIAGNOSIS >

Diagnostic Worksheet

INFOID:000000006059728



SQUEAK & RATTLE DIAGNOSTIC WORKSHEET

Dear Infiniti Customer:

We are concerned about your satisfaction with your Infiniti vehicle. Repairing a squeak or rattle sometimes can be very difficult. To help us fix your Infiniti right the first time, please take a moment to note the area of the vehicle where the squeak or rattle occurs and under what conditions. You may be asked to take a test drive with a service consultant or technician to ensure we confirm the noise you are hearing.

I. WHERE DOES THE NOISE COME FROM? (circle the area of the vehicle)

The illustrations are for reference only, and may not reflect the actual configuration of your vehicle.

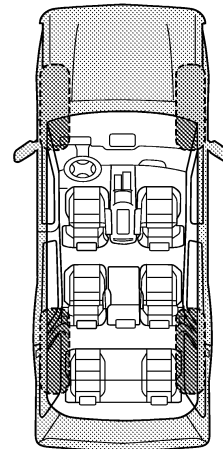
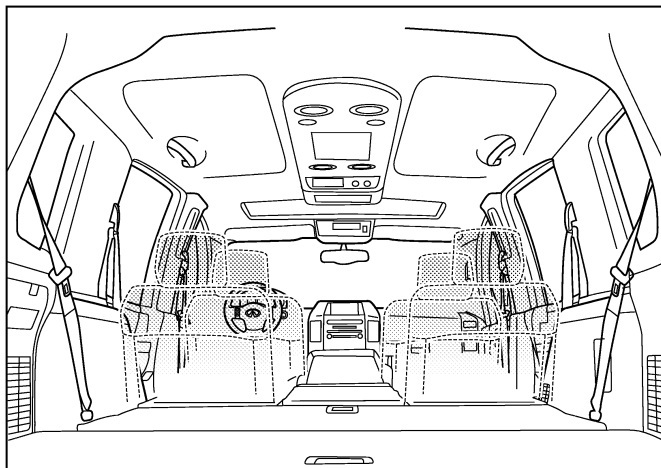
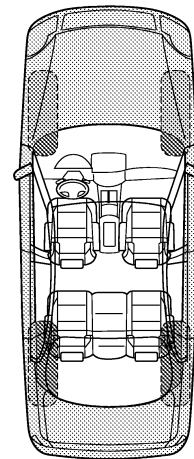
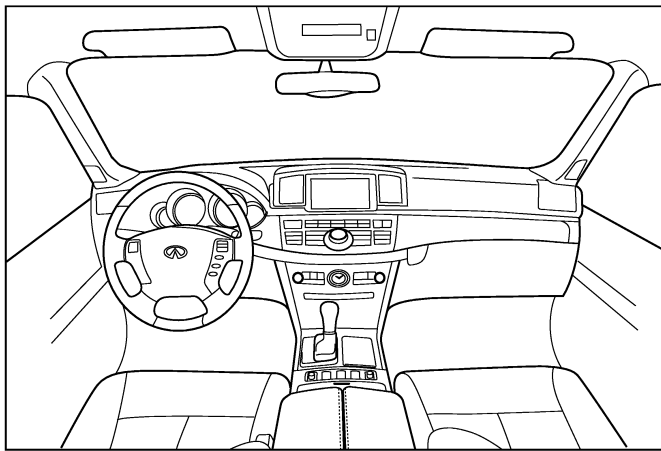

Continue to page 2 of the worksheet and briefly describe the location of the noise or rattle. In addition, please indicate the conditions which are present when the noise occurs.

PIIB8741E

SQUEAK AND RATTLE TROUBLE DIAGNOSES

< SYMPTOM DIAGNOSIS >

SQUEAK & RATTLE DIAGNOSTIC WORKSHEET - page 2

Briefly describe the location where the noise occurs:

II. WHEN DOES IT OCCUR? (please check the boxes that apply)

- | | |
|---|--|
| <input type="checkbox"/> anytime | <input type="checkbox"/> after sitting out in the rain |
| <input type="checkbox"/> 1st time in the morning | <input type="checkbox"/> when it is raining or wet |
| <input type="checkbox"/> only when it is cold outside | <input type="checkbox"/> dry or dusty conditions |
| <input type="checkbox"/> only when it is hot outside | <input type="checkbox"/> other: |

III. WHEN DRIVING:

- through driveways
- over rough roads
- over speed bumps
- only about ____ mph
- on acceleration
- coming to a stop
- on turns: left, right or either (circle)
- with passengers or cargo
- other: _____
- after driving ____ miles or ____ minutes

IV. WHAT TYPE OF NOISE

- squeak (like tennis shoes on a clean floor)
- creak (like walking on an old wooden floor)
- rattle (like shaking a baby rattle)
- knock (like a knock at the door)
- tick (like a clock second hand)
- thump (heavy, muffled knock noise)
- buzz (like a bumble bee)

TO BE COMPLETED BY DEALERSHIP PERSONNEL

Test Drive Notes:

	YES	NO	Initials of person performing
Vehicle test driven with customer	<input type="checkbox"/>	<input type="checkbox"/>	_____
- Noise verified on test drive	<input type="checkbox"/>	<input type="checkbox"/>	_____
- Noise source located and repaired	<input type="checkbox"/>	<input type="checkbox"/>	_____
- Follow up test drive performed to confirm repair	<input type="checkbox"/>	<input type="checkbox"/>	_____

VIN: _____ Customer Name: _____
W.O.# _____ Date: _____

This form must be attached to Work Order

PIIB8742E

A
B
C
D
E
F
G
H
I
INT
K
L
M
N
O
P

FRONT DOOR FINISHER

< REMOVAL AND INSTALLATION >

REMOVAL AND INSTALLATION

FRONT DOOR FINISHER

Exploded View

INFOID:000000006046569

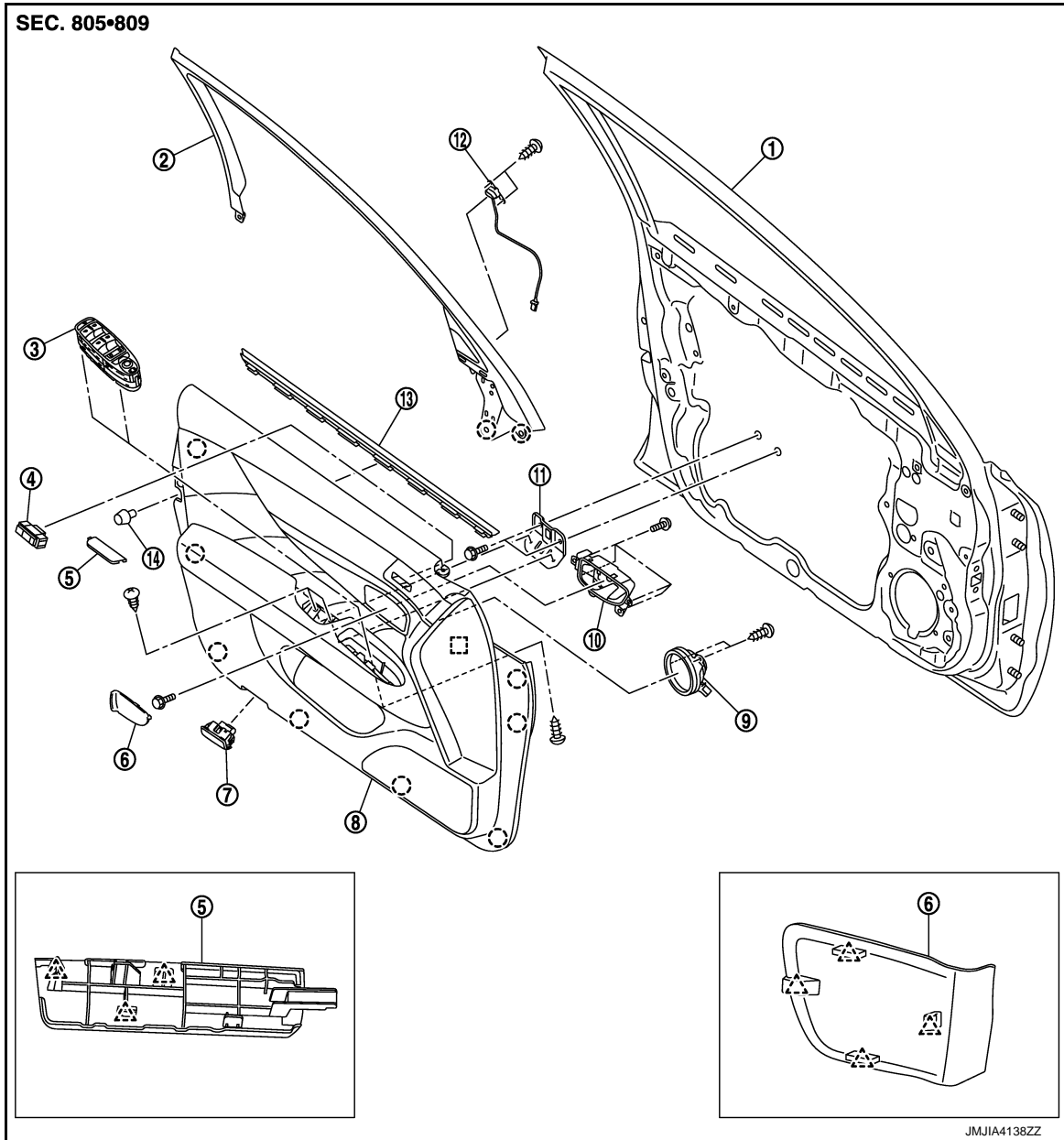

- | | | |
|------------------------------|--------------------------------|-----------------------------|
| 1. Front door panel | 2. Front door sash inner cover | 3. Power window switch |
| 4. Seat memory switch | 5. Armrest cap | 6. Inside handle escutcheon |
| 7. Step lamp | 8. Front door finisher | 9. Front door squawker |
| 10. Front door inside handle | 11. Pull handle bracket | 12. BSW/BSI indicator |
| 13. Front door inside seal | 14. Bumper rubber | |

- : Clip
 △ : Pawl
 □ : Metal clip

FRONT DOOR FINISHER

FRONT DOOR FINISHER

< REMOVAL AND INSTALLATION >

FRONT DOOR FINISHER : Removal and Installation

INFOID:00000006046570

REMOVAL

1. Remove inside handle escutcheon.
 1. Insert a flat-bladed screwdriver (A) between inside handle escutcheon (1) and inside handle assembly to disengage pawls.
 2. Pull back inside handle escutcheon.

CAUTION:

Apply protective tape (B) to flat-bladed screwdriver.

 : Pawl

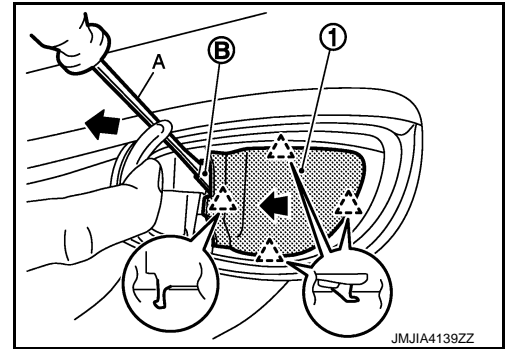

2. Remove screw located on the back side of inside handle escutcheon.
3. Remove armrest cap.

1. Insert a remover tool (A) between armrest cap (1) and front door finisher assembly and disengage pawls.
2. Pull toward the direction of the arrows as shown in the figure to remove armrest cap.

 : Pawl

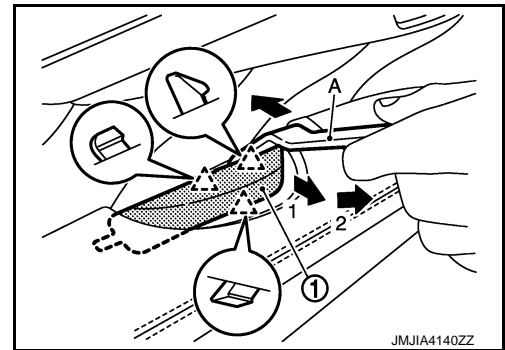

4. Remove screws located on back side of armrest.
5. Rotate bumper rubber to left side, and pull back to remove.

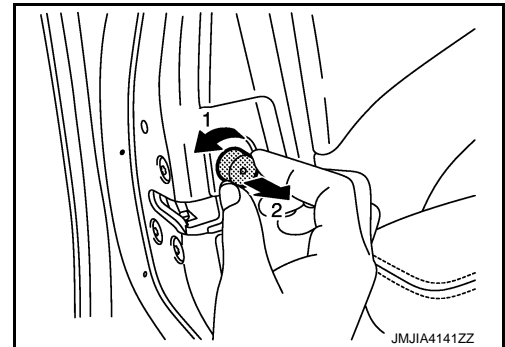

6. Remove step lamp. Refer to [INL-74, "Removal and Installation"](#).
7. Insert a remover tool (A) between front door finisher and front door panel to disengage the fixing clips and metal clip.
8. Pull toward the direction of the arrows as shown in the figure to remove.

 : Clip

 : Metal clip

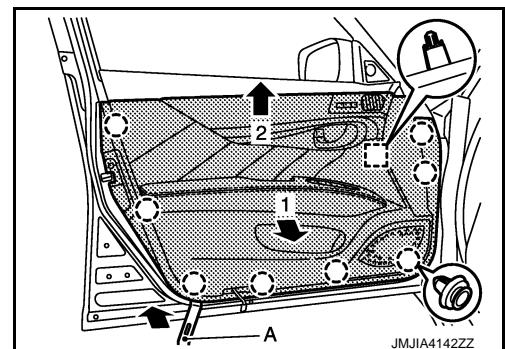

A
B
C
D
E
F
G
H
I
INT
K
L
M
N
O
P

FRONT DOOR FINISHER

< REMOVAL AND INSTALLATION >

9. Disconnect the lock knob cable (1) and inside handle cable (2) from door inside handle assembly (3).

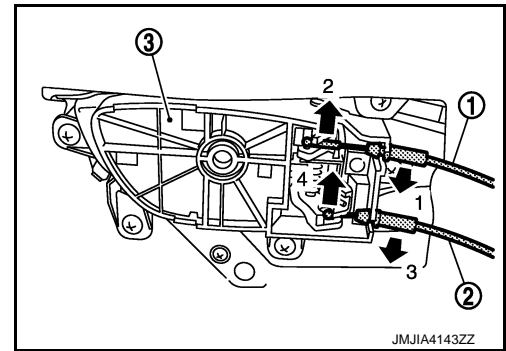

10. Disconnect seat memory switch harness connector (with ADP). Refer to [ADP-149. "Removal and Installation"](#).
11. Disconnect front squawker harness connector. Refer to [AV-300. "Removal and Installation"](#).
12. Disconnect power window switch harness connector. Refer to [PWC-72. "Removal and Installation"](#).
13. Remove front door finisher.
14. Remove parts as per the following list after removing front door finisher.
 - Front door inside handle assembly: Refer to [DLK-176. "INSIDE HANDLE : Removal and Installation"](#).
 - Seat memory switch (with ADP): Refer to [ADP-149. "Removal and Installation"](#).
 - Front power window switch: Refer to [PWC-72. "Removal and Installation"](#).
 - Front door squawker: Refer to [AV-300. "Removal and Installation"](#).

INSTALLATION

Note the following items, and then install in the reverse order of removal.

CAUTION:

- **Never damage harness while installing.**
- **When installing door finisher, check that all clips are securely fitted in panel holes on body, and then press clips and metal clip in.**

FRONT DOOR SASH INNER COVER

FRONT DOOR SASH INNER COVER : Removal and Installation

INFOID:000000006046571

REMOVAL

1. Remove front door finisher. Refer to [INT-31. "FRONT DOOR FINISHER : Removal and Installation"](#).
2. Disconnect tweeter harness connector. Refer to [AV-301. "Removal and Installation"](#).
3. Disconnect BSW/BSI indicator harness connector. Refer to [DAS-594. "Removal and Installation"](#).
4. Disengage front door sash inner cover fixing clips, and then remove front door sash inner cover.

INSTALLATION

Note the following item, and then install in the reverse order of removal.

CAUTION:

- **When installing front door sash inner cover, check that clips are securely fitted in panel holes on door, and then press clips in.**

REAR DOOR FINISHER

< REMOVAL AND INSTALLATION >

REAR DOOR FINISHER

Exploded View

INFOID:000000006046572

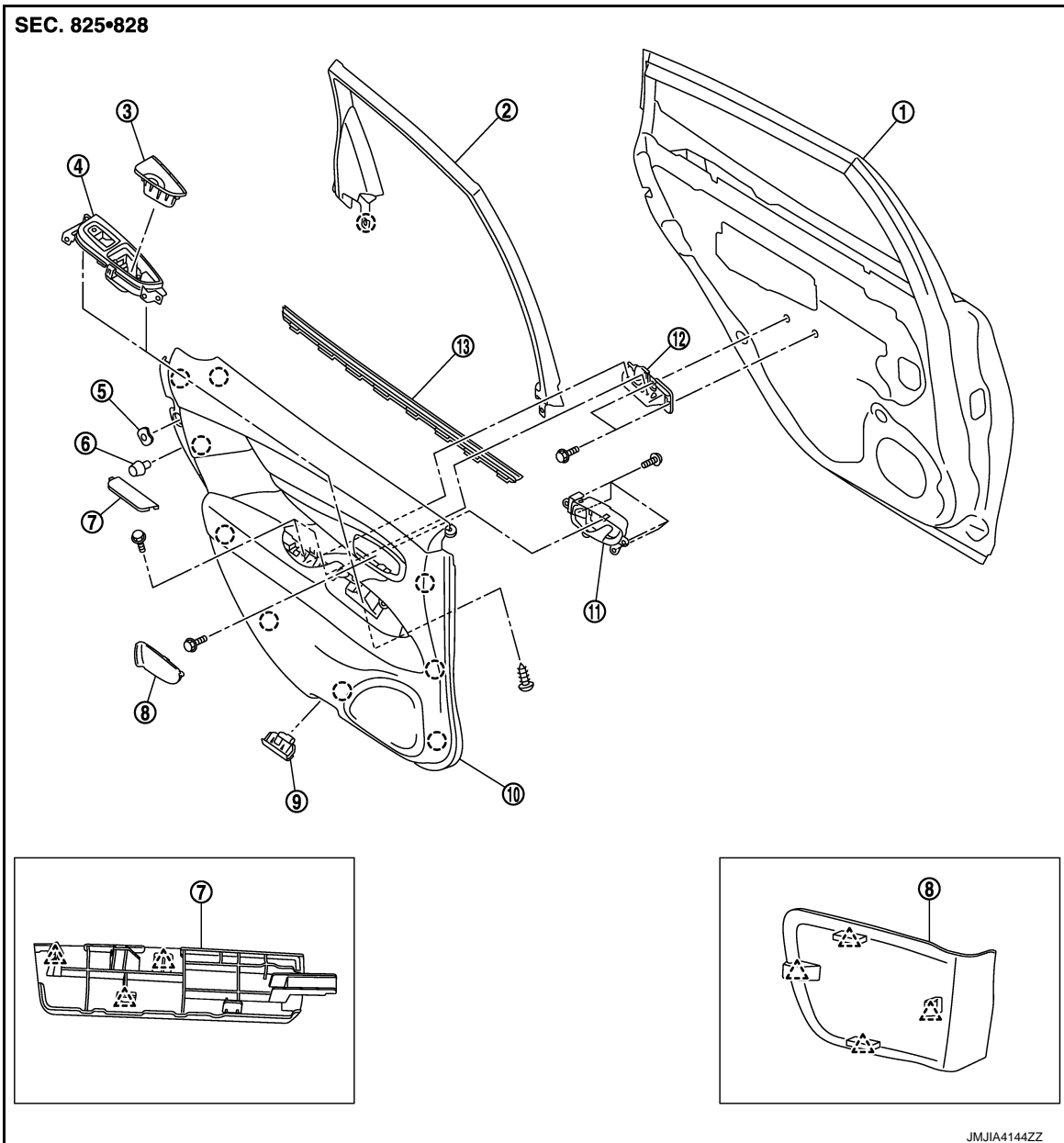

- | | | |
|---------------------------|-------------------------------|-------------------------|
| 1. Rear door panel | 2. Rear door sash inner cover | 3. Ashtray |
| 4. Power window switch | 5. Child lock cover | 6. Bumper rubber |
| 7. Armrest cap | 8. Inside handle escutcheon | 9. Step lamp |
| 10. Rear door finisher | 11. Rear door inside handle | 12. Pull handle bracket |
| 13. Rear door inside seal | | |

- : Clip
 △ : Pawl

REAR DOOR FINISHER

REAR DOOR FINISHER : Removal and Installation

INFOID:000000006046573

REMOVAL

A
B
C
D
E
F
G
H
I
INT
K
L
M
N
O
P

REAR DOOR FINISHER

< REMOVAL AND INSTALLATION >

1. Fully open door window.
2. Remove ashtray.
 1. Lift up ashtray.
 2. Remove ashtray.

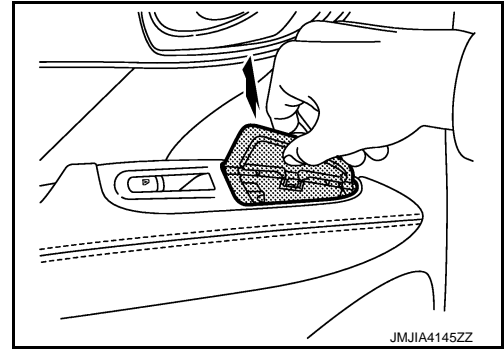

3. Remove inside handle escutcheon.
 1. Insert a flat-bladed screwdriver (A) between inside handle escutcheon (1) and inside handle assembly and disengage pawls.
 2. Pull back inside handle escutcheon.

CAUTION:

Apply protective tape (B) to flat-bladed screwdriver.

 : Pawl

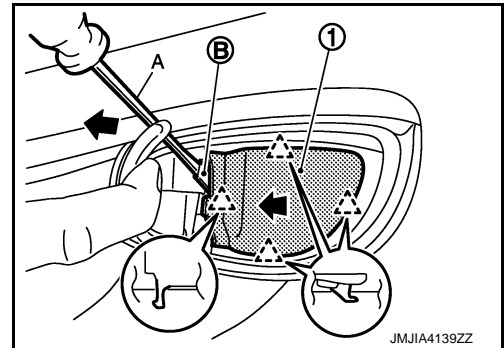

4. Remove screw located on back side of inside handle escutcheon.
5. Remove armrest cap.
 1. Insert a remover tool (A) between armrest cap (1) and front door finisher assembly and disengage pawls.
 2. Pull toward the direction of the arrow as shown in the figure to remove armrest cap.

 : Pawl

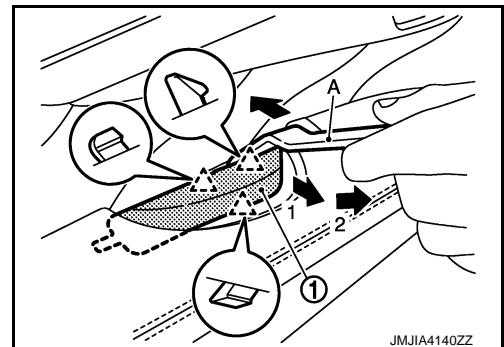

6. Remove screws located on the back side of armrest.
7. Rotate bumper rubber to left side, and pull back to remove.

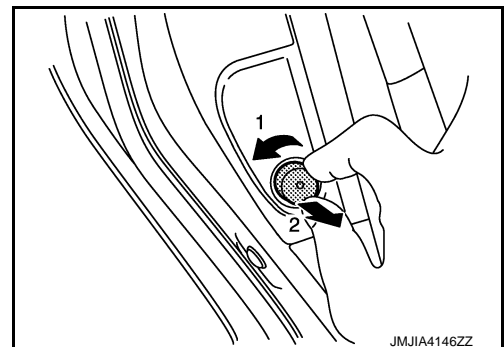

8. Remove step lamp. Refer to [INL-74, "Removal and Installation"](#).

REAR DOOR FINISHER

< REMOVAL AND INSTALLATION >

9. Insert a remover tool (A) between the rear door finisher and rear door panel to disengage the fixing clips and metal clip.
10. Pull out front door finisher and pull up toward vehicle inside.

 : Clip

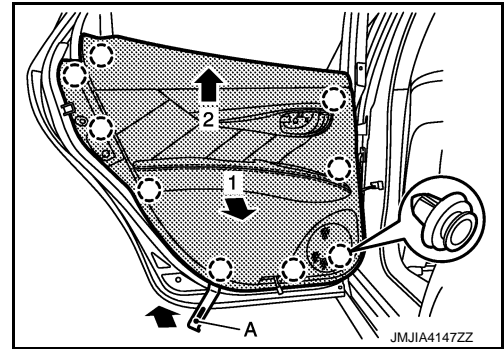

11. Disconnect the lock knob cable (1) and inside handle cable (2) from door inside handle assembly (3).

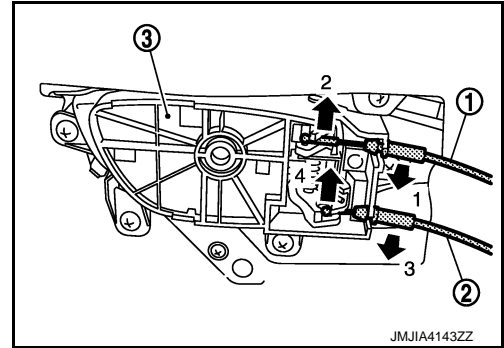

12. Disconnect rear power window switch connector.
13. Remove rear door finisher.
14. Remove as per the following list after removing rear door finisher.
 - Door inside handle assembly: Refer to [DLK-179, "INSIDE HANDLE : Removal and Installation"](#).
 - Rear power window switch: Refer to [PWC-73, "Removal and Installation"](#).
 - Child lock cover

INSTALLATION

Note the following item, and then install in the reverse order of removal.

CAUTION:

When installing door finisher, check that all clips are securely fitted in panel holes on body, and then press clips in.

REAR DOOR SASH INNER COVER

REAR DOOR SASH INNER COVER : Removal and Installation

INFOID:000000006046574

REMOVAL

1. Remove rear door finisher. Refer to [INT-31, "FRONT DOOR FINISHER : Removal and Installation"](#).
2. Disengage rear door sash inner cover fixing clips, and then remove rear door sash inner cover.

INSTALLATION

Note the following item, and then install in the reverse order of removal.

CAUTION:

When installing rear door sash inner cover, check that clips are securely fitted in panel holes on door, and then press clips in.

BODY SIDE TRIM

< REMOVAL AND INSTALLATION >

BODY SIDE TRIM

Exploded View

INFOID:000000006046575

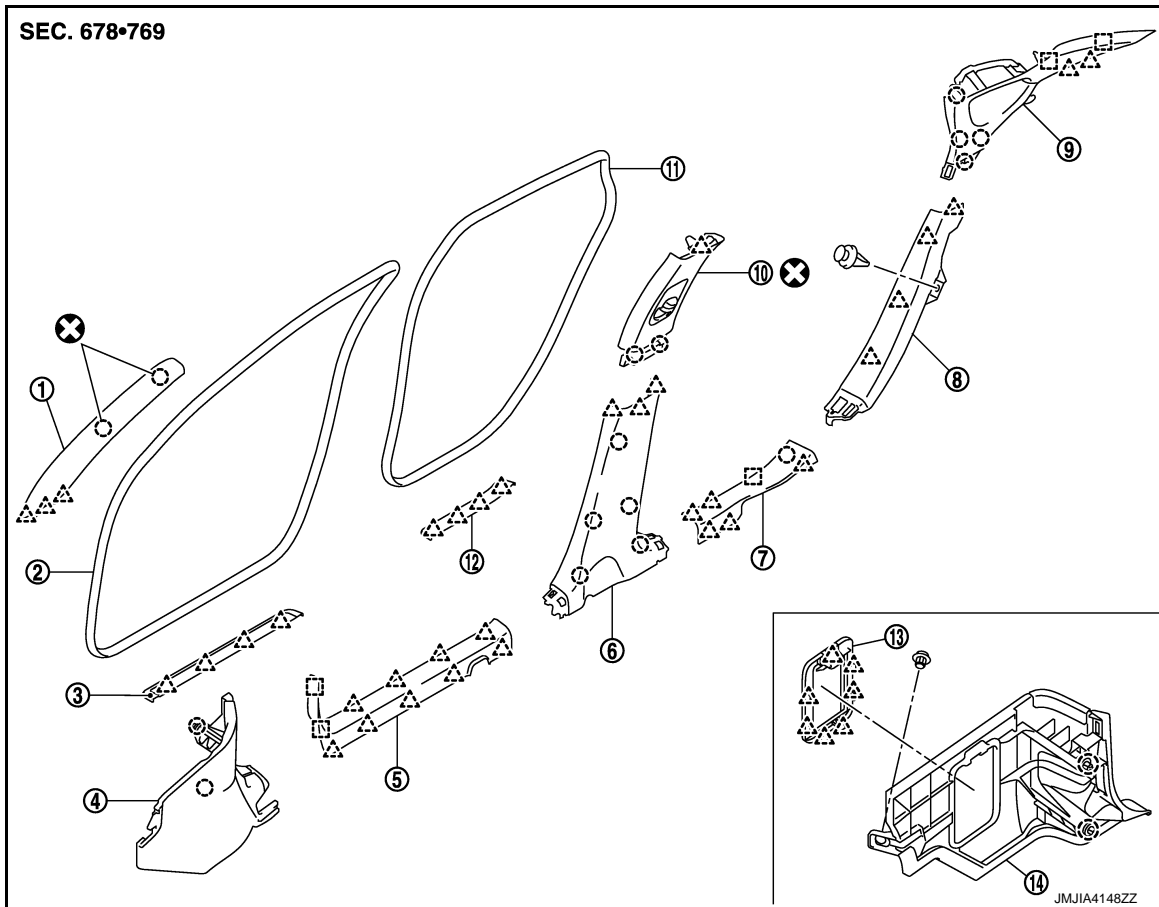

- | | | |
|---------------------------------|------------------------------|--------------------------------|
| 1. Front pillar garnish | 2. Front body side welt | 3. Front kicking plate outer |
| 4. Dash side finisher RH | 5. Front kicking plate inner | 6. Center pillar lower garnish |
| 7. Rear kicking plate inner | 8. Rear wheel house garnish | 9. Rear pillar finisher |
| 10. Center pillar upper garnish | 11. Rear body side welt | 12. Rear kicking plate outer |
| 13. Fuse lid (driver side) | 14. Dash side finisher LH | |

○ : Clip

△ : Pawl

□ : Metal clip

Refer to [GI-4, "Components"](#) for symbols in the figure.

FRONT PILLAR GARNISH

FRONT PILLAR GARNISH : Removal and Installation

INFOID:000000006046576

CAUTION:

- When removing, always use a remover tool that is made of plastic.
- Never damage the body.

REMOVAL

1. Remove front body side welt partially.

BODY SIDE TRIM

< REMOVAL AND INSTALLATION >

2. Insert a remover tool (A) into the clearance between front pillar garnish and vehicle body to make work space, and then cut the clips.
3. Pull up front pillar garnish to remove.

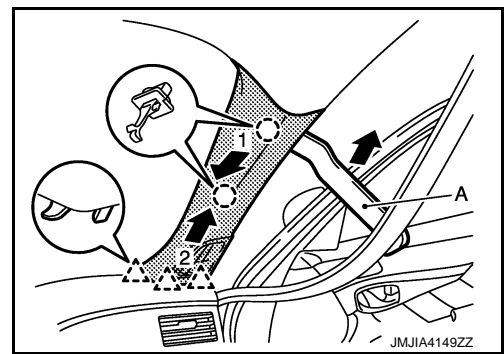
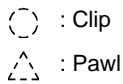

INSTALLATION

Note the following items, and then install in the reverse order of removal.

CAUTION:

- When installing, check that all clips and pawls are securely fitted in panel holes on body, and then press clips and pawls in.
- Never reuse clips.

KICKING PLATE OUTER

KICKING PLATE OUTER : Removal and Installation

INFOID:000000006046577

CAUTION:

- When removing, always use a remover tool that is made of plastic.
- Never damage the body.

REMOVAL

FRONT KICKING PLATE OUTER

1. Insert a remover tool (A) between front kicking plate outer and body panel to disengage pawls.
2. Pull up front kicking plate outer to remove.

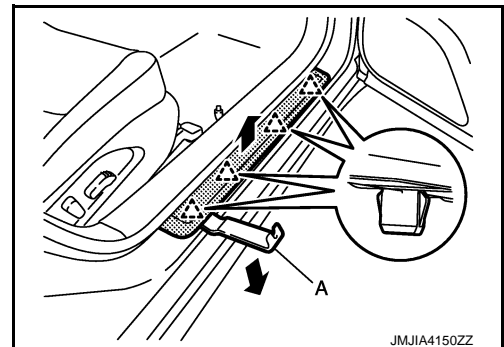
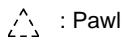

REAR KICKING PLATE OUTER

1. Insert a remover tool between rear kicking plate outer and body panel to disengage pawls.
2. Pull up rear kicking plate outer to remove.

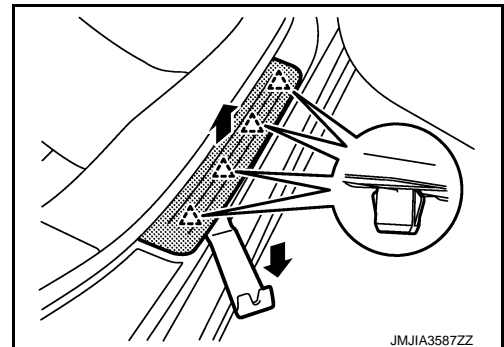
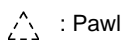

INSTALLATION

Note the following item, and then install in the reverse order of removal.

CAUTION:

- Check that pawls are securely fitted in panel holes on body when installing, and then press pawls in.

KICKING PLATE INNER

BODY SIDE TRIM

< REMOVAL AND INSTALLATION >

KICKING PLATE INNER : Removal and Installation

INFOID:000000006046578

CAUTION:

- When removing, always use a remover tool that is made of plastic.
- Never damage the body.

REMOVAL

FRONT KICKING PLATE INNER

1. Insert a remover tool between front kicking plate inner and body side panel to disengage metal clip on the front side.
2. Pull up front kicking plate inner starting from rear side to disengage pawls.

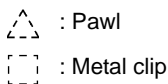
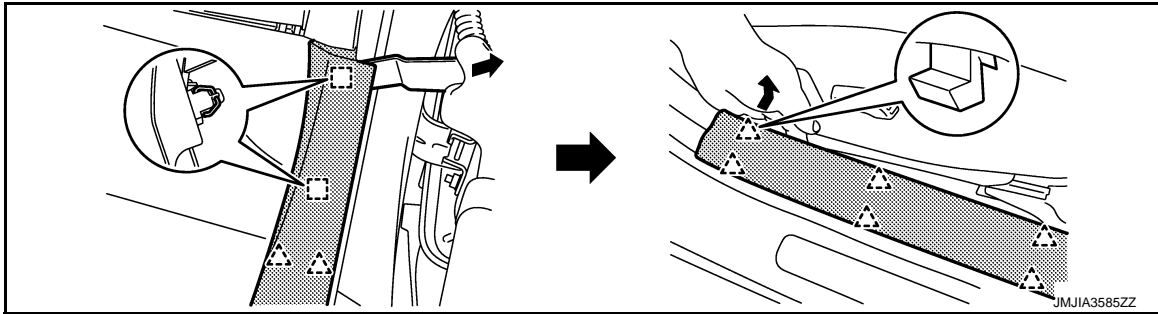

REAR KICKING PLATE INNER

1. Insert a remover tool between rear kicking plate inner and body side panel, and disengage clip and pawls.
2. Move rear kicking plate inner back and forth to disengage metal clip.

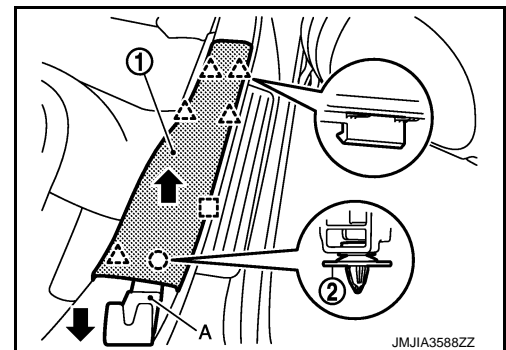

INSTALLATION

Note the following items, and then install in the reverse order of removal.

CAUTION:

- Check that watertight packing is attached to clip.
- When installing, check that all clips, pawls, and metal clips are securely fitted in panel holes on body, and then press clips, pawls, and metal clips in.

DASH SIDE FINISHER

DASH SIDE FINISHER : Removal and Installation

INFOID:000000006046579

CAUTION:

- When removing, always use a remover tool that is made of plastic.
- Never damage the body.

DRIVER SIDE (DASH SIDE FINISHER LH)

Removal

1. Remove front kicking plate inner LH. Refer to [INT-38, "KICKING PLATE INNER : Removal and Installation"](#).

BODY SIDE TRIM

< REMOVAL AND INSTALLATION >

2. Remove clip (A).
3. Insert remover tool (B) between dash side finisher (1) and body side panel to disengage clips.

 : Clip

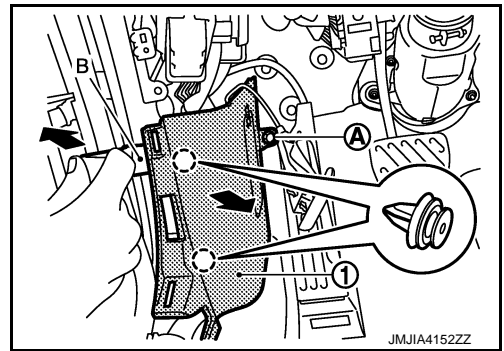

4. Pull back dash side finisher LH to remove.

Installation

Note the following item, and then install in the reverse order of removal.

CAUTION:

When installing, check that all clips are securely fitted in panel holes on body, and then press clips in.

PASSENGER SIDE (DASH SIDE FINISHER RH)

Removal

1. Remove front kicking plate inner RH. Refer to [INT-38. "KICKING PLATE INNER : Removal and Installation"](#).
2. Remove instrument lower cover. Refer to [IP-13. "Removal and Installation"](#).
3. Insert remover tool (A) between dash side finisher RH (1) and body side panel to disengage clips.

 : Clip

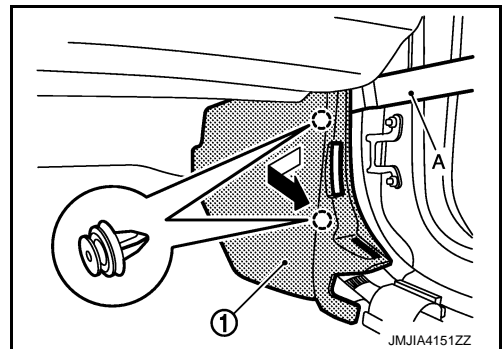

4. Pull back dash side finisher RH to remove.

Installation

Note the following item, and install in the reverse order of removal.

CAUTION:

When installing, check that all clips are securely fitted in panel holes on body, and then press clips in.

BODY SIDE WELT

BODY SIDE WELT : Removal and Installation

INFOID:0000000006046580

CAUTION:

- When removing, always use a remover tool that is made of plastic.
- Never damage the body.

REMOVAL

FRONT BODY SIDE WELT

1. Remove front kicking plate inner and rear kicking plate inner. Refer to [INT-38. "KICKING PLATE INNER : Removal and Installation"](#).
2. Remove center pillar lower garnish. Refer to [INT-40. "CENTER PILLAR LOWER GARNISH : Removal and Installation"](#).
3. Remove center pillar upper garnish. Refer to [INT-40. "CENTER PILLAR UPPER GARNISH : Removal and Installation"](#).

BODY SIDE TRIM

< REMOVAL AND INSTALLATION >

4. Remove front body side welt.

REAR BODY SIDE WELT

1. Remove front kicking plate inner and rear kicking plate inner. Refer to [INT-38, "KICKING PLATE INNER : Removal and Installation"](#).
2. Remove center pillar lower garnish. Refer to [INT-40, "CENTER PILLAR LOWER GARNISH : Removal and Installation"](#).
3. Remove center pillar upper garnish. Refer to [INT-40, "CENTER PILLAR UPPER GARNISH : Removal and Installation"](#).
4. Remove rear body side welt.

INSTALLATION

Install in the reverse order of removal.

CENTER PILLAR LOWER GARNISH

CENTER PILLAR LOWER GARNISH : Removal and Installation

INFOID:000000006046581

CAUTION:

- When removing, always use a remover tool that is made of plastic.
- Never damage the body.

REMOVAL

1. Remove front kicking plate inner and rear kicking plate inner. Refer to [INT-38, "KICKING PLATE INNER : Removal and Installation"](#).
2. Insert a remover tool between body panel and center pillar lower garnish to disengage the fixing clips and pawls as shown in the figure.

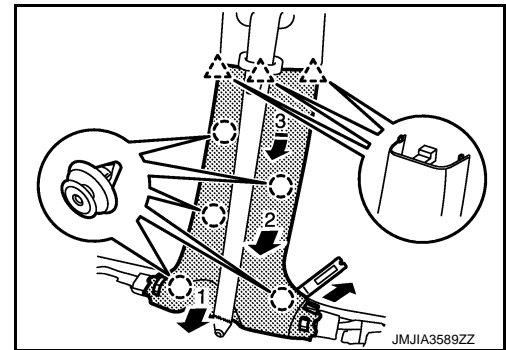
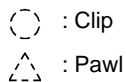

3. Pull back center pillar lower garnish to remove.

INSTALLATION

Note the following item, and then install in the reverse order of removal.

CAUTION:

Check that clips are securely fitted in panel holes on body when installing, and then press clips in.

CENTER PILLAR UPPER GARNISH

CENTER PILLAR UPPER GARNISH : Removal and Installation

INFOID:000000006046582

CAUTION:

- When removing, always use a remover tool that is made of plastic.
- Never damage the body.

REMOVAL

1. Remove center pillar lower garnish. Refer to [INT-40, "CENTER PILLAR LOWER GARNISH : Removal and Installation"](#).
2. Remove front seat belt retractor mounting anchor bolt. Refer to [SB-6, "SEAT BELT RETRACTOR : Removal and Installation"](#).

BODY SIDE TRIM

< REMOVAL AND INSTALLATION >

- Remove center pillar upper garnish fixing clips with a remover tool.

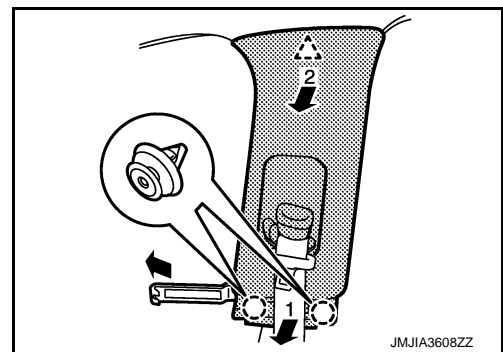
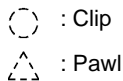

- Pull center pillar upper garnish from inside passenger room, and then disengage the pawl shown in the figure to remove the garnish from the vehicle.

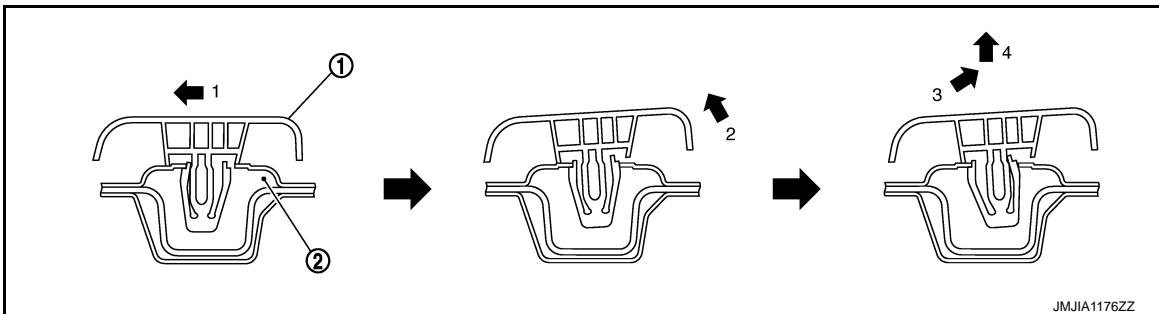

CAUTION:

Be careful not to apply excessive force when removing center pillar upper garnish. Otherwise, pawl may be damaged and fragments may drop in panel holes on body.

INSTALLATION

Note the following items, and then install in the reverse order of removal.

CAUTION:

- Replace center pillar upper garnish with a new part after removal. Never reuse center pillar upper garnish.
- Check that clips and pawl are securely fitted in panel holes on body when installing, and then press clips and pawl in.

REAR WHEEL HOUSE GARNISH

REAR WHEEL HOUSE GARNISH : Removal and Installation

INFOID:000000006046583

CAUTION:

- When removing, always use a remover tool that is made of plastic.
- Never damage the body.

REMOVAL

- Remove rear seat cushion and rear seatback. Refer to [SE-117, "Removal and Installation"](#).
- Remove rear seat belt retractor anchor bolt (LH and RH). Refer to [SB-12, "SEAT BELT RETRACTOR : Removal and Installation"](#).
- Remove rear kicking plate inner. Refer to [INT-38, "KICKING PLATE INNER : Removal and Installation"](#).
- Remove clip (A).
- Insert a remover tool between rear wheel house garnish and body panel to disengage the pawls as shown in the figure.

NOTE:

Remove according to the steps indicated in the figure to avoid damaging the fixing pawls.

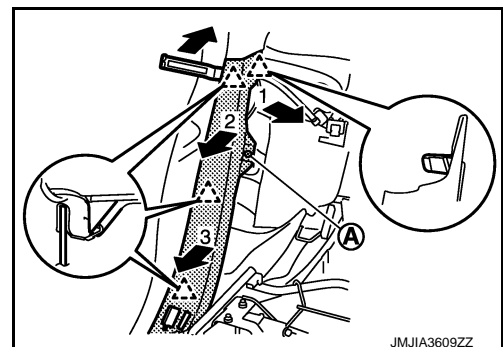
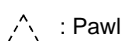

BODY SIDE TRIM

< REMOVAL AND INSTALLATION >

6. Remove rear wheel house garnish from the body panel.

INSTALLATION

Note the following item, and then install in the reverse order of removal.

CAUTION:

**Check that pawls are securely fitted in panel holes on body when installing, and then press pawls in.
REAR PILLAR FINISHER**

REAR PILLAR FINISHER : Removal and Installation

INFOID:000000006046584

CAUTION:

- When removing, always use a remover tool that is made of plastic.
- Never damage the body.

REMOVAL

1. Remove rear seat cushion and rear seatback. Refer to [SE-117, "Removal and Installation"](#).
2. Remove rear kicking plate inner. Refer to [INT-38, "KICKING PLATE INNER : Removal and Installation"](#).
3. Remove rear body side welt from rear pillar finisher side. Refer to [INT-39, "BODY SIDE WELT : Removal and Installation"](#).
4. Remove rear wheel house garnish. Refer to [INT-41, "REAR WHEEL HOUSE GARNISH : Removal and Installation"](#).
5. Remove rear seat belt retractor anchor bolt (LH and RH). Refer to [SB-12, "SEAT BELT RETRACTOR : Removal and Installation"](#).
6. Insert a remover tool between rear pillar finisher and body side panel to disengage the clips, pawls, and metal clips.

NOTE:

Remove according to the steps indicated in the figure to avoid damaging the rear pillar finisher.

- : Clip
- △ : Pawl
- : Metal clip

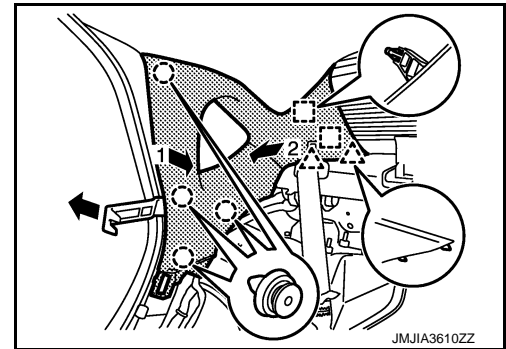

INSTALLATION

Note the following items, and then install in the reverse order of removal.

CAUTION:

- Check that clips, pawls, and metal clips are securely fitted in panel holes on body when installing, and then press clips, pawls, and metal clips in.
- When installing, check that pawl of rear pillar finisher (1) is engaged to rear parcel shelf finisher (2).

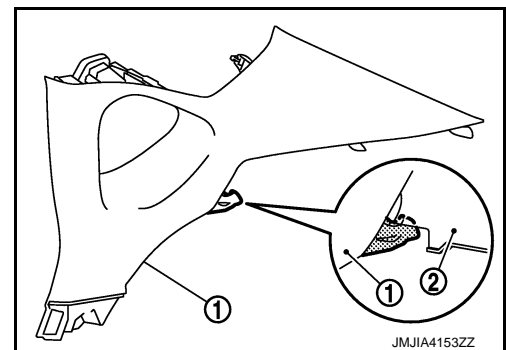

REAR PARCEL SHELF FINISHER

< REMOVAL AND INSTALLATION >

REAR PARCEL SHELF FINISHER

Exploded View

INFOID:000000006046585

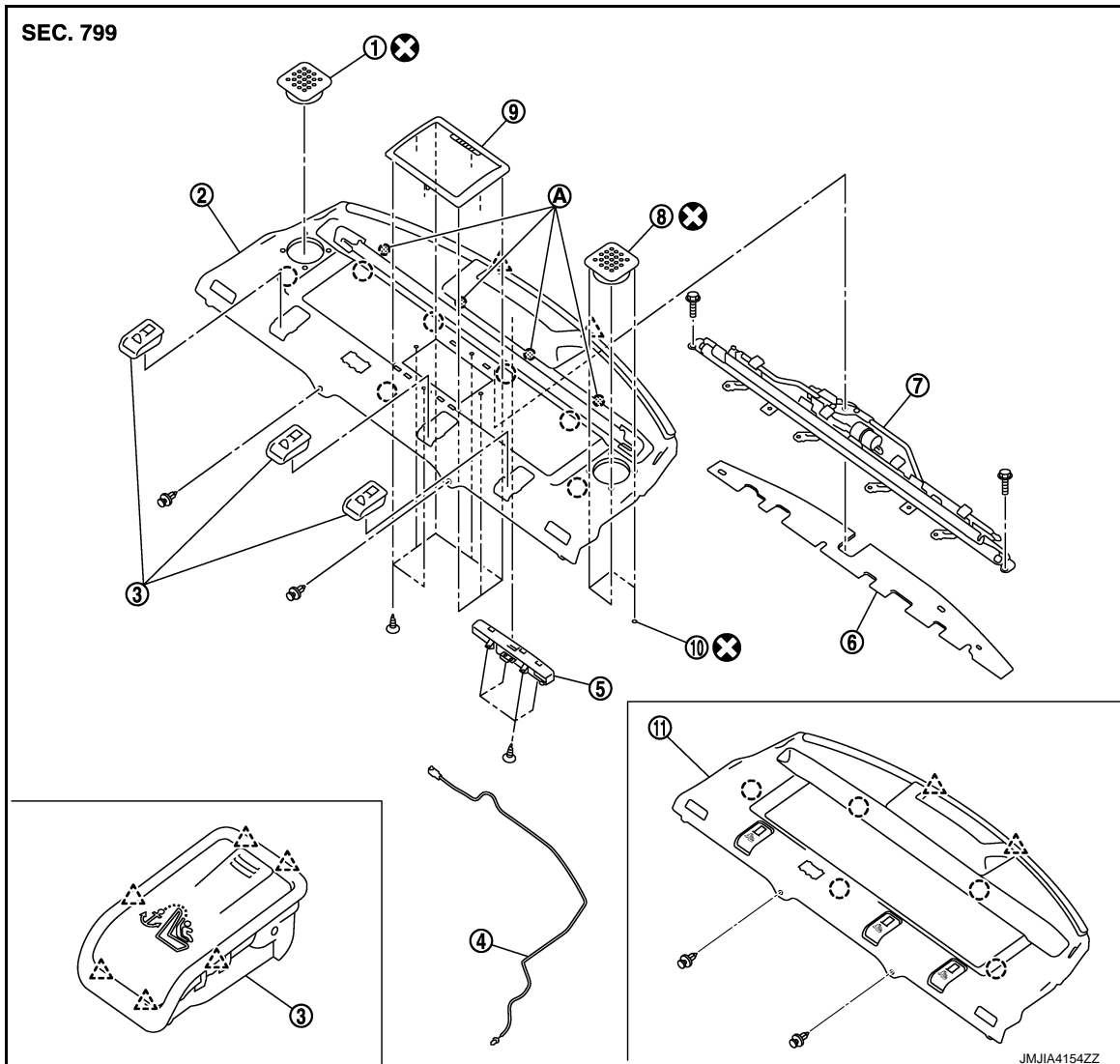

- | | | |
|---------------------------------------|---|-----------------------|
| 1. Rear speaker grille RH | 2. Rear parcel shelf finisher (with sunshade) | 3. Child anchor cover |
| 4. High-mounted stop lamp sub harness | 5. High-mounted stop lamp | 6. Felt |
| 7. Rear window sunshade | 8. Rear speaker grille LH | 9. Woofer grille |
| 10. Push on nut | 11. Rear parcel shelf finisher (without sunshade) | |

A : Dual lock fastener

○ : Clip

△ : Pawl

Refer to [GI-4. "Components"](#) for symbols in the figure.

Removal and Installation

INFOID:000000006046586

REMOVAL

1. Remove rear seatback and rear seat cushion. Refer to [SE-117. "Removal and Installation"](#).
2. Remove rear seat belt floor anchor bolts. Refer to [SB-12. "SEAT BELT RETRACTOR : Removal and Installation"](#).

A
B
C
D
E
F
G
H
I
INT
K
L
M
N
O
P

REAR PARCEL SHELF FINISHER

< REMOVAL AND INSTALLATION >

3. Remove rear kicking plate inner (LH and RH). Refer to [INT-38. "KICKING PLATE INNER : Removal and Installation"](#).
4. Remove rear wheelhouse garnish (LH and RH). Refer to [INT-41. "REAR WHEEL HOUSE GARNISH : Removal and Installation"](#).
5. Remove rear pillar finisher (LH and RH). Refer to [INT-42. "REAR PILLAR FINISHER : Removal and Installation"](#).
6. Disengage child anchor cover (LH and RH) fixing pawls with a remover tool and then remove child anchor cover (LH and RH).

 : Pawl

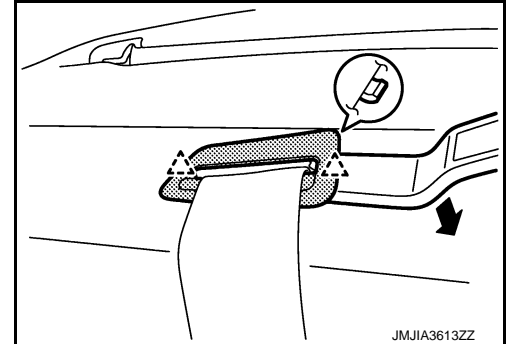

7. Hold rear parcel shelf finisher (1) from both sides, pull it upward to disengage the clips, and then disconnect high-mounted stop lamp harness connector (A) located on the left side only.

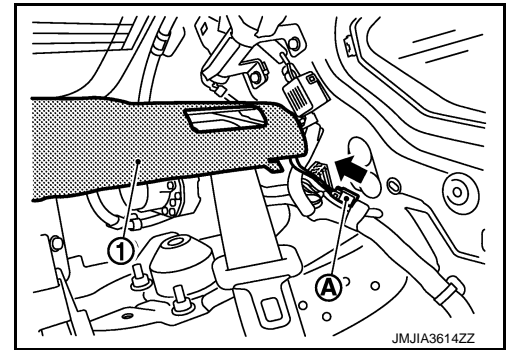

8. Remove rear parcel shelf finisher from vehicle body.
 - With sunshade: Disengage clips on the back side and dual lock fastener (models with sunshade only), and then pull out toward vehicle front.
 - Without sunshade: Disengage clips on the back side, and then pull out toward vehicle front.

INSTALLATION

Note the following items, and then install in the reverse order of removal.

CAUTION:

- Check that clips are securely fitted in panel holes on body when installing, and then press them in.
- Check the following after installation.
 - From inside passenger room, check that black print on rear window glass is visible.
 - From outside passenger room, check that there is a clearance between rear window glass and high-mounted stop lamp cover of approximately 5.0 mm (0.197 in).
 - From rear sunshade opening, check for engagement of pawls (models with sunshade).

FLOOR TRIM

< REMOVAL AND INSTALLATION >

FLOOR TRIM

Exploded View

INFOID:000000006046587

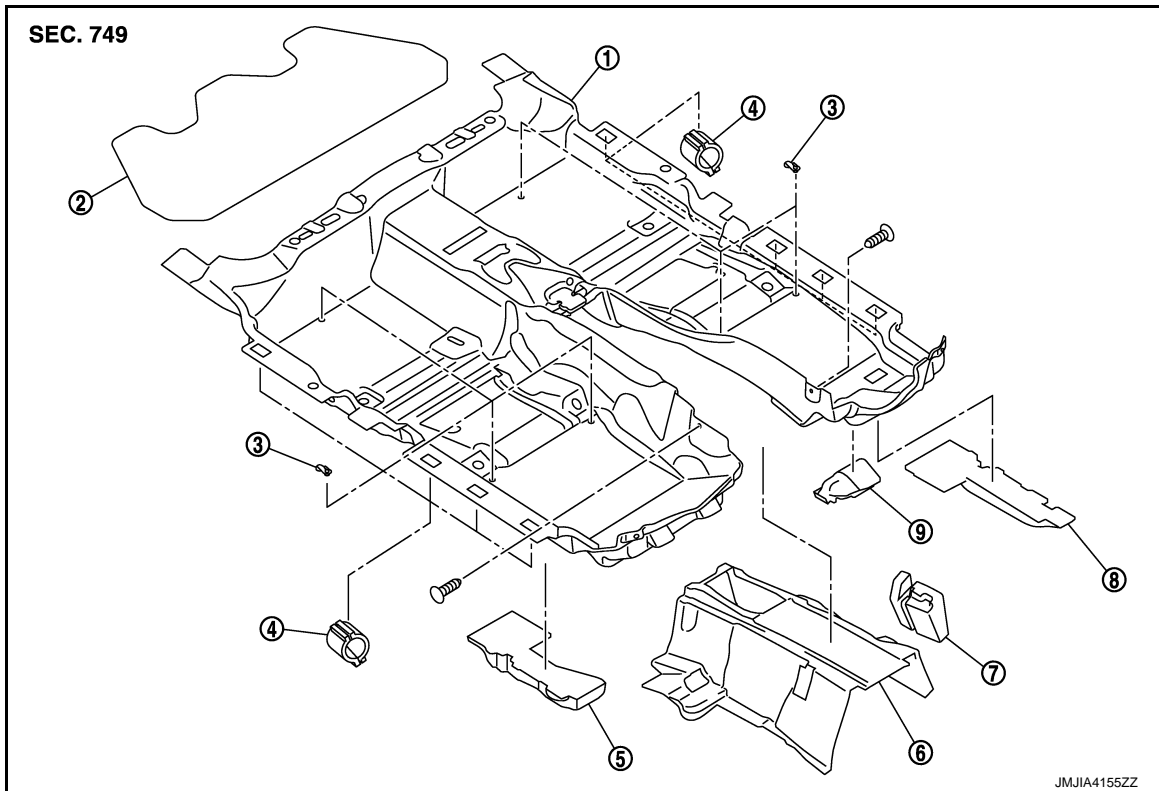

- | | | |
|----------------------------|--------------------------|------------------------------|
| 1. Floor carpet assembly | 2. Floor insulator | 3. Carpet hook |
| 4. Carpet fixing clip | 5. Front floor spacer RH | 6. Front floor center spacer |
| 7. Front floor side spacer | 8. Front floor spacer LH | 9. Footrest |

Removal and Installation

INFOID:000000006046588

REMOVAL

1. Remove front seat assembly (LH and RH). Refer to [SE-108, "Removal and Installation"](#).
2. Remove accelerator pedal assembly.
 - Models without distance control assist system: Refer to [ACC-3, "MODELS WITHOUT DISTANCE CONTROL ASSIST SYSTEM : Removal and Installation"](#).
 - Models with distance control assist system: Refer to [ACC-4, "MODELS WITH DISTANCE CONTROL ASSIST SYSTEM : Removal and Installation"](#).
3. Remove front kicking plate inner (LH and RH). Refer to [INT-38, "KICKING PLATE INNER : Removal and Installation"](#).
4. Remove dash side finisher (LH and RH). Refer to [INT-38, "DASH SIDE FINISHER : Removal and Installation"](#).
5. Remove front body side welt (LH and RH). Refer to [INT-39, "BODY SIDE WELT : Removal and Installation"](#).
6. Remove rear seat cushion. Refer to [SE-117, "Removal and Installation"](#).
7. Remove rear kicking plate inner (LH and RH). Refer to [INT-38, "KICKING PLATE INNER : Removal and Installation"](#).
8. Remove center pillar lower garnish (LH and RH). Refer to [INT-40, "CENTER PILLAR LOWER GARNISH : Removal and Installation"](#).
9. Remove rear body side welt (LH and RH). Refer to [INT-39, "BODY SIDE WELT : Removal and Installation"](#).

A
B
C
D
E
F
G
H
I

INT

K
L
M
N
O
P

FLOOR TRIM

< REMOVAL AND INSTALLATION >

10. Disengage pawls of floor hook (1) with remover tool, and then remove floor hook.

 : Pawl

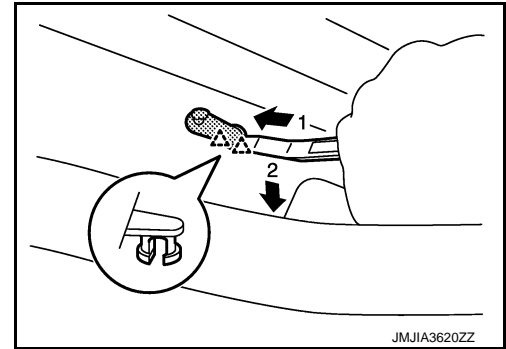

11. Remove front seat belt floor anchor bolts (LH and RH). Refer to [SB-6, "SEAT BELT RETRACTOR : Removal and Installation"](#).
12. Remove center console assembly. Refer to [IP-24, "Removal and Installation"](#).
13. Remove the following parts after removing the center console assembly.

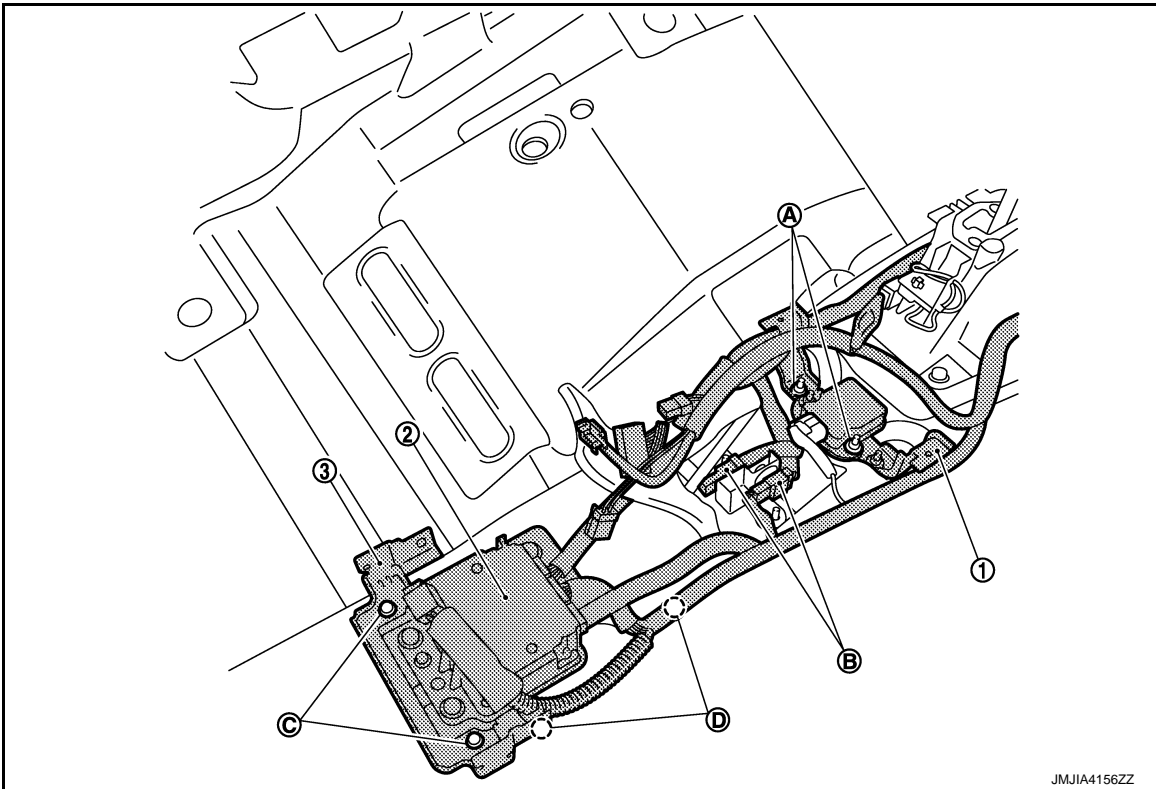

1. Remove bolts (A), and then remove console front bracket (1).
 2. Pull up floor carpet and disconnect harness connectors (B).
 3. Remove diagnosis sensor unit. Refer to [SR-25, "Removal and Installation"](#).
 4. Remove bolts (C), and then remove console rear bracket (3).
 5. Remove harness clips (D).
14. Remove floor trim from floor trim fixing clips (A).

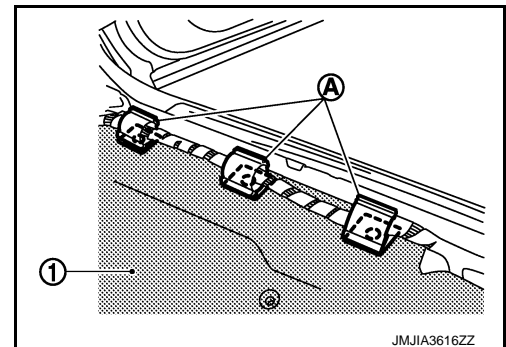

FLOOR TRIM

< REMOVAL AND INSTALLATION >

15. Pass each harness through a floor carpet opening, toward vehicle floor, so that each harness is free from floor carpet. Remove floor carpet from the vehicle body.

INSTALLATION

Install in the reverse order of removal.

A

B

C

D

E

F

G

H

I

INT

K

L

M

N

O

P

HEADLINING

< REMOVAL AND INSTALLATION >

HEADLINING

Exploded View

INFOID:000000006046591

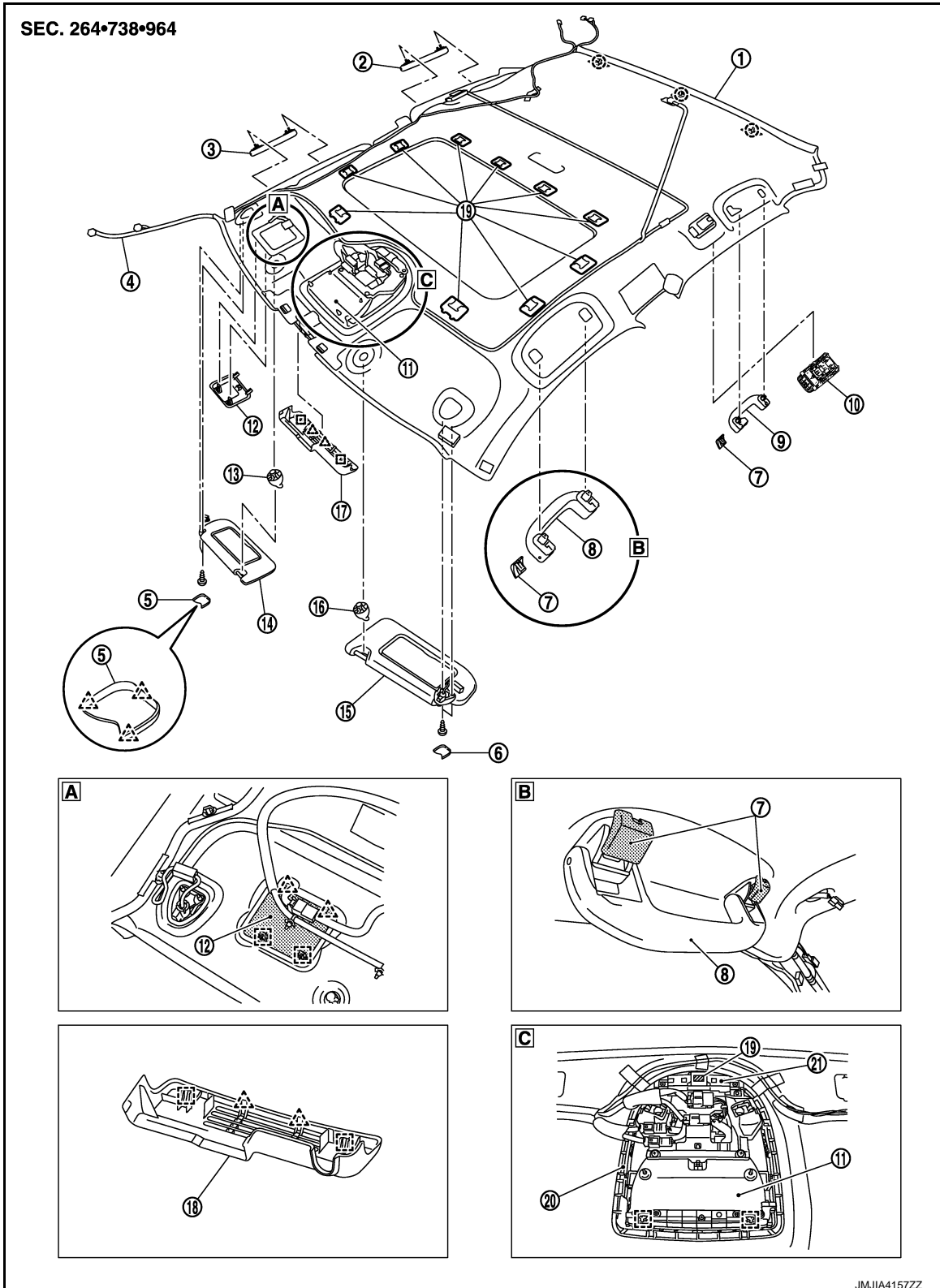

- 1. Headlining assembly
- 4. Antenna feeder
- 7. Assist grip clip

- 2. Rear assist grip RH
- 5. Sun visor cap RH
- 8. Front assist grip LH

- 3. Front assist grip RH
- 6. Sun visor cap LH
- 9. Rear assist grip LH

HEADLINING

< REMOVAL AND INSTALLATION >

- | | | |
|----------------------------|---|--|
| 10. Personal lamp assembly | 11. Roof console assembly | 12. Front roof finisher |
| 13. Sun visor holder RH | 14. Sun visor assembly RH | 15. Sun visor assembly LH |
| 16. Sun visor holder LH | 17. Front camera finisher (without LDW&LDP) | 18. Front camera finisher (with LDW&LDP) |
| 19. Dual lock fastener | 20. Roof plate | 21. Map lamp bracket |

 : Clip

 : Pawl

 : Metal clip

Removal and Installation

INFOID:000000006046592

REMOVAL

- Remove front seat assembly (LH and RH). Refer to [SE-108, "Removal and Installation"](#).
- Remove rear seat cushion and rear seatback. Refer to [SE-117, "Removal and Installation"](#).
- Remove center console assembly. Refer to [IP-24, "Removal and Installation"](#).
- Remove A/T shift selector.
 - 2WD models: Refer to [TM-175, "2WD : Removal and Installation"](#).
 - AWD models: Refer to [TM-177, "AWD : Removal and Installation"](#).
- Remove front kicking plate inner (LH and RH). Refer to [INT-38, "KICKING PLATE INNER : Removal and Installation"](#).
- Remove rear kicking plate inner (LH and RH). Refer to [INT-38, "KICKING PLATE INNER : Removal and Installation"](#).
- Remove front body side welt (LH and RH) and rear body side welt (LH and RH). Refer to [INT-36, "FRONT PILLAR GARNISH : Removal and Installation"](#).
- Remove front pillar garnish (LH and RH). Refer to [INT-36, "FRONT PILLAR GARNISH : Removal and Installation"](#).
- Disconnect roof harness connectors (A), and then remove harness clip (B) as shown in the figure.

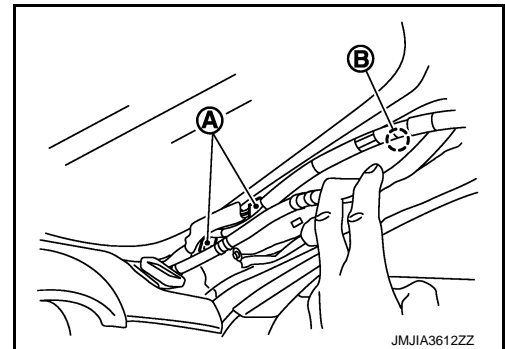

- Remove sun visor assembly (LH and RH).
 - Insert a flat-bladed screwdriver (A) between sun visor cap and sun visor assembly, and disengage pawls.
 - Pull back sun visor cap (LH and RH) to remove.

 : Pawl

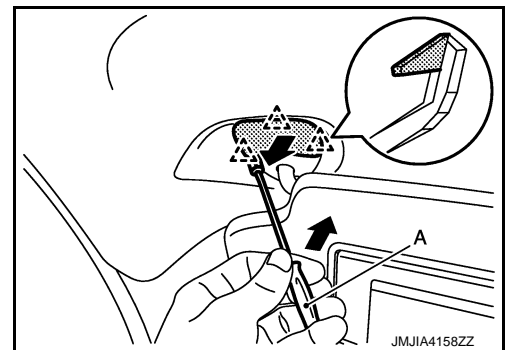

- Remove sun visor assembly fixing screws.
- Disconnect vanity mirror lamp harness connector.
- Remove front roof finisher.

HEADLINING

< REMOVAL AND INSTALLATION >

1. Insert a remover tool between front roof finisher and headlining, and disengage pawls and metal clips.
2. Pull down front roof finisher to remove.

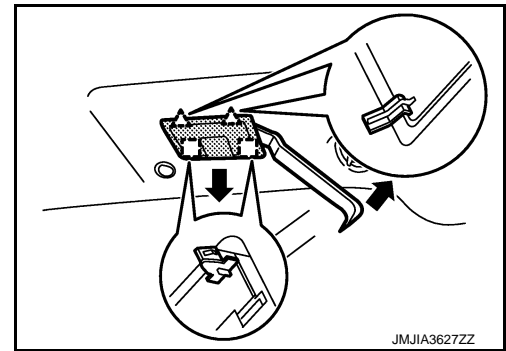
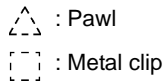

12. Remove front camera finisher.

1. Insert a remover tool between front camera finisher and headlining, and disengage pawls and metal clips.
2. Pull down front camera finisher to remove.

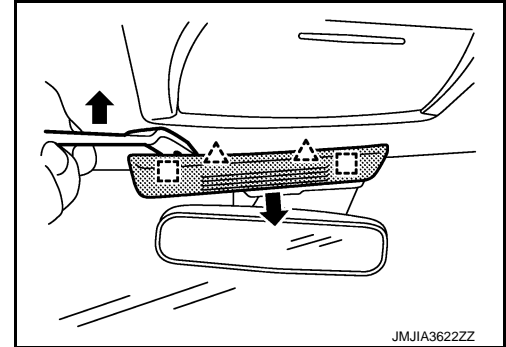
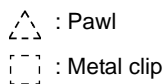

13. Disconnect lane camera unit harness connector.

14. Remove rain sensor cover, and then disconnect harness connector. Refer to [WW-60. "Removal and Installation"](#).

15. Remove center pillar lower garnish (LH and RH). Refer to [INT-40. "CENTER PILLAR LOWER GARNISH : Removal and Installation"](#).

16. Remove center pillar upper garnish (LH and RH). Refer to [INT-40. "CENTER PILLAR UPPER GARNISH : Removal and Installation"](#).

17. Remove rear wheel house garnish (LH and RH). Refer to [INT-41. "REAR WHEEL HOUSE GARNISH : Removal and Installation"](#).

18. Remove rear pillar finisher (LH and RH). Refer to [INT-42. "REAR PILLAR FINISHER : Removal and Installation"](#).

19. Remove all assist grips.

1. Remove fixing pawl of assist grip clip (A) using a flat-bladed screwdriver (B), and then remove assist grip clip.
2. Remove assist grip (1).

NOTE:

When removing assist grip clip, metal clip remains on the vehicle body side.

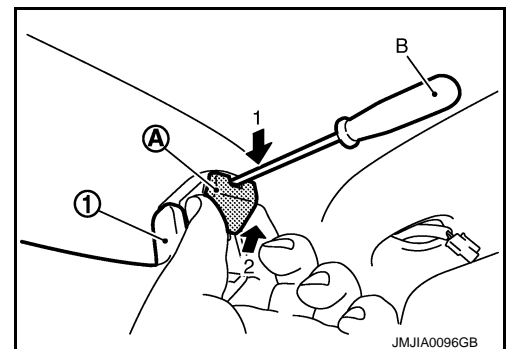

HEADLINING

< REMOVAL AND INSTALLATION >

20. On the rear right side of the vehicle, disconnect the harness connector (A) and (C), and then remove the ground cable fixing bolt (B).
21. Remove harness clips.

 : Clip (harness clip)

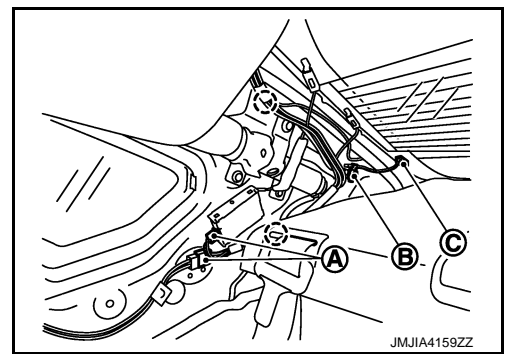

22. Remove body side mounting plastic clip from rear end of headlining using a remover tool.
23. Remove sun-visor holder (LH and RH).

Insert a small flat-bladed screwdriver (A) into the hole of the sun-visor holder (1), press while rotating approximately 90 degrees to remove.

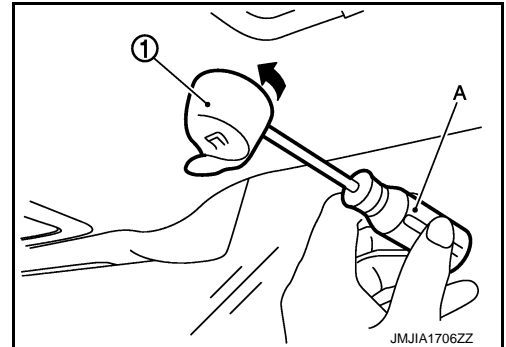

24. Insert a remover tool between the headlining and roof panel, and disengage metal clips (B).
25. Pull down roof console assembly to disengage joint dual-lock fastener (A).

CAUTION:

- When removing, always use a remover tool that is made of plastic.
- Roof console assembly is crimped from back of headlining. Remove roof console assembly after removing headlining from the vehicle.

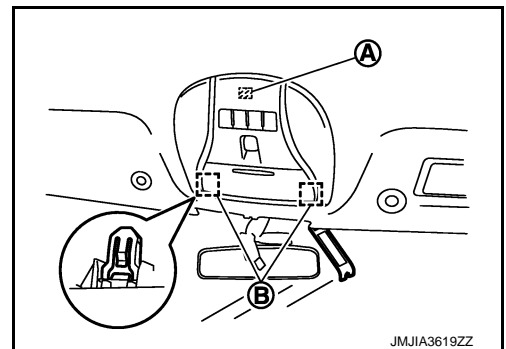

26. Remove headlining assembly as shown in the figure below.

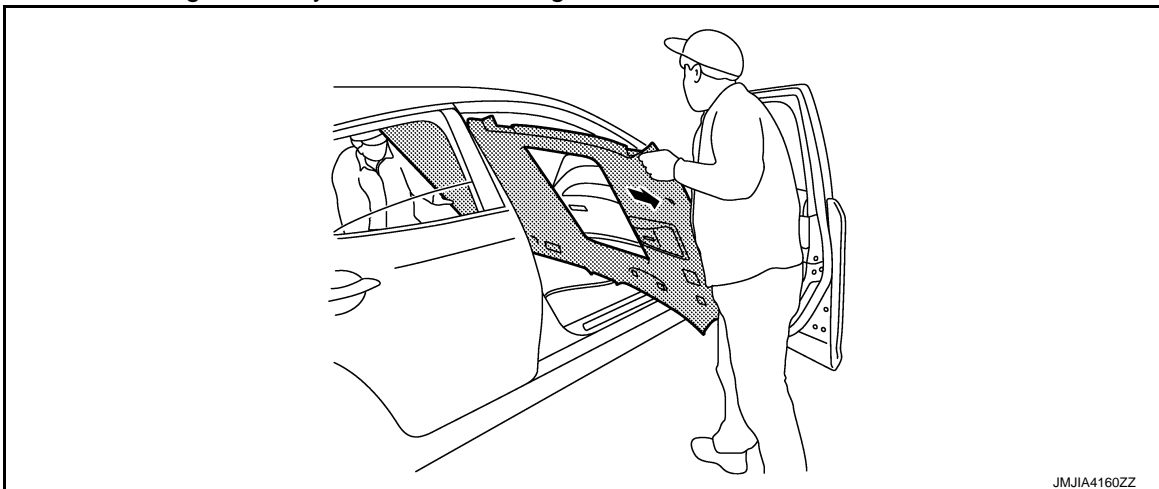

CAUTION:

- When removing, 2 workers are required. (1 for the front and rear of headlining)
- Apply protective tape to the portion where contact may occur during work.
- Never bend headlining when removing.

27. Remove the following parts after removing headlining.

HEADLINING

< REMOVAL AND INSTALLATION >

- Antenna feeder: Refer to [AV-140, "Feeder Layout"](#).
- Personal lamp: Refer to [INL-75, "Removal and Installation"](#).

INSTALLATION

Note the following items, and then install in the reverse order of removal.

CAUTION:

- Install headlining assembly after inserting clips to clip holder of headlining rear end.
- Never bend headlining when installing.
- When installing assist grip, install metal clip (1) to assist grip clip (2), and then install to the vehicle body.

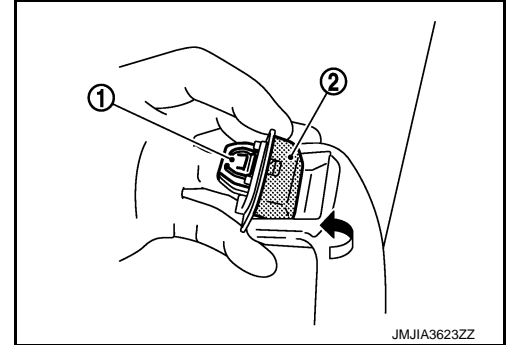

Removal and Installation of Map Lamp Assembly

Removal

1. Remove harness connector (A).
2. Remove screws (B), and then remove map lamp bracket (1).
3. Remove roof plate (3) from headlining while pressing engagement of each pawls in the direction as shown in the figure.

CAUTION:

When removing, support map lamp (2) by hand so that it does not drop during the operation.

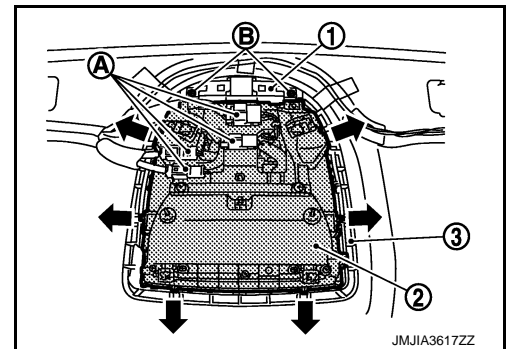

Installation

Install in the reverse order of removal.

TRUNK ROOM TRIM

< REMOVAL AND INSTALLATION >

TRUNK ROOM TRIM

Exploded View

INFOID:000000006046593

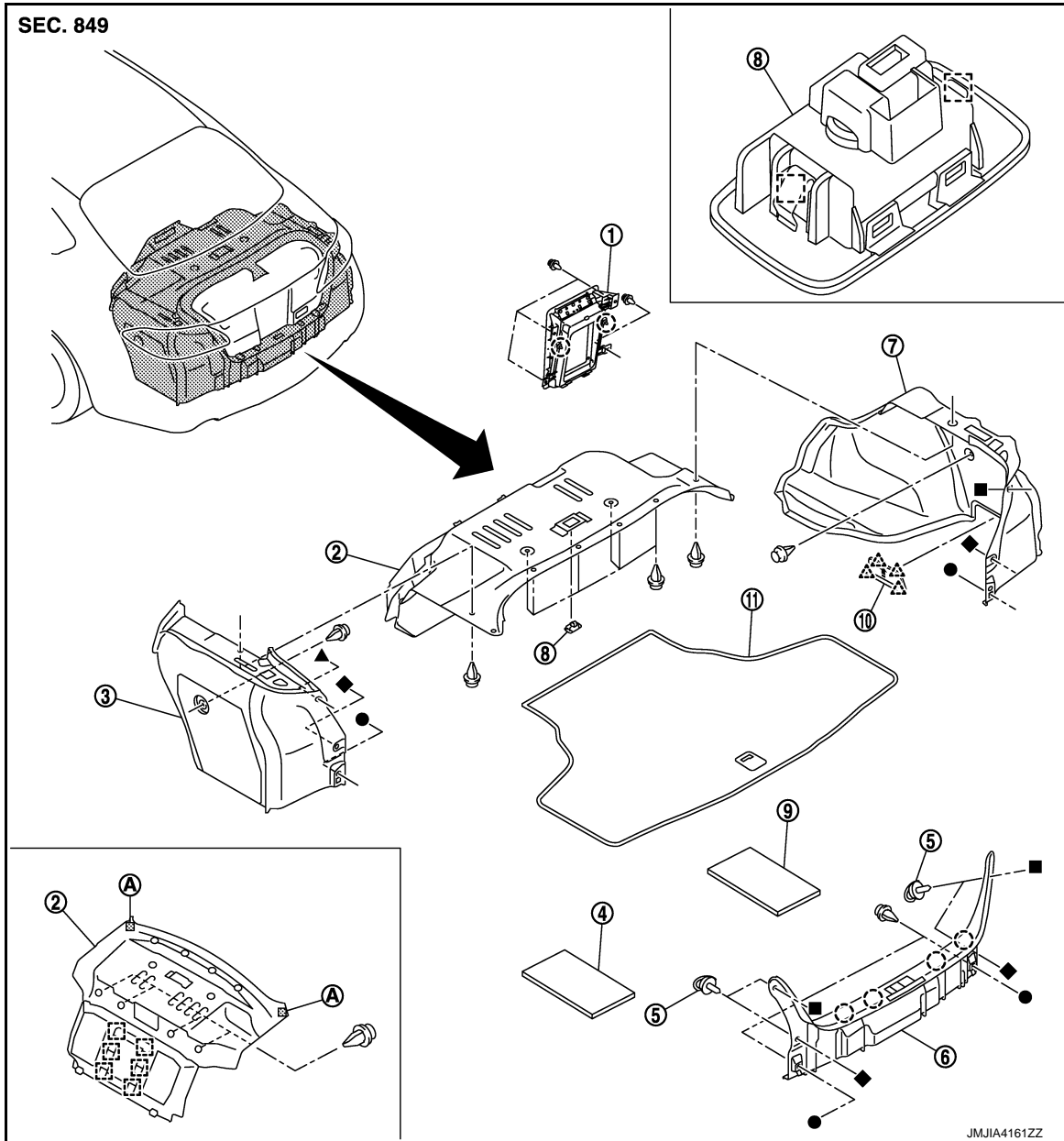

- | | | |
|----------------------------------|-------------------------|---------------------------|
| 1. Rear seatback center finisher | 2. Trunk front finisher | 3. Trunk side finisher LH |
| 4. Trunk floor board LH | 5. Rope hook | 6. Trunk rear plate |
| 7. Trunk side finisher RH | 8. Trunk room lamp | 9. Trunk floor board RH |
| 10. Trunk side finisher cover | 11. Trunk floor carpet | |

A : Dual lock fastener

○ : Clip

△ : Pawl

□ : Metal clip

TRUNK REAR PLATE

A
B
C
D
E
F
G
H
I
INT
K
L
M
N
O
P

TRUNK ROOM TRIM

< REMOVAL AND INSTALLATION >

TRUNK REAR PLATE : Removal and Installation

INFOID:000000006046594

REMOVAL

1. Fully open trunk lid.
2. Remove trunk floor carpet.
3. Remove rope hooks and trunk rear plate fixing clips
4. Insert a remover tool between trunk rear plate and body rear panel to disengage fixing clips, and then remove luggage rear plate.

- : Clip
⇐ : Vehicle front

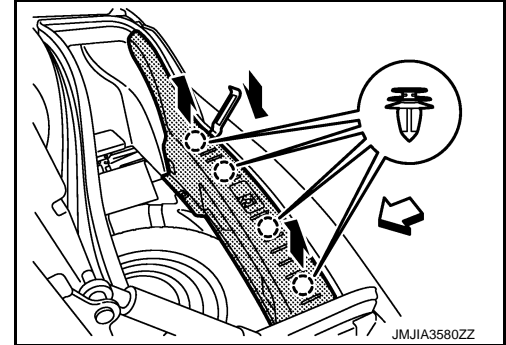

5. Pull up trunk rear plate to remove.

INSTALLATION

Note the following item, and then install in the reverse order of removal.

CAUTION:

Check that clips are securely fitted in panel holes on body when installing, and then press clips in.

TRUNK FINISHER FRONT

TRUNK FINISHER FRONT : Removal and Installation

INFOID:000000006046595

REMOVAL

1. Fully open trunk lid assembly.
2. Remove trunk room lamp (luggage side). Refer to [INL-78. "Removal and Installation"](#).
3. Remove trunk floor carpet.
4. Remove trunk lid weather-strip. Refer to [DLK-167. "TRUNK LID WEATHER-STRIP : Removal and Installation"](#).
5. Remove trunk front finisher fixing clips.
6. Insert a remover tool between the rear seatback center finisher and trunk front finisher to disengage the metal clips.
7. Pull down trunk front finisher, and disengage dual-lock fasteners.
8. Remove trunk front finisher from the vehicle.

INSTALLATION

Note the following item, and then install in the reverse order of removal.

CAUTION:

Check that metal clips are securely fitted in panel holes on body when installing, and then metal clips in.

TRUNK SIDE FINISHER

TRUNK SIDE FINISHER : Removal and Installation

INFOID:000000006046596

REMOVAL

1. Fully open trunk lid assembly.
2. Remove trunk rear plate. Refer to [INT-54. "TRUNK REAR PLATE : Removal and Installation"](#).
3. Remove trunk front finisher. Refer to [INT-54. "TRUNK FINISHER FRONT : Removal and Installation"](#).
4. Insert a remover tool between the trunk side finisher and trunk side finisher cover to disengage the pawls.
5. Remove trunk side finisher cover.

TRUNK ROOM TRIM

< REMOVAL AND INSTALLATION >

6. Remove trunk side finisher fixing clips.
7. Remove trunk side finisher from the vehicle.

A

INSTALLATION

Install in the reverse order of removal.

REAR SEATBACK CENTER FINISHER

B

REAR SEATBACK CENTER FINISHER : Removal and Installation

INFOID:000000006046597

C

REMOVAL

1. Remove rear seatback assembly. Refer to [SE-117. "Disassembly and Assembly"](#).
2. Remove rear seatback center finisher fixing clips, and then remove rear seatback center finisher.

D

INSTALLATION

Install in the reverse order of removal.

E

F

G

H

I

INT

K

L

M

N

O

P

TRUNK LID TRIM

< REMOVAL AND INSTALLATION >

TRUNK LID TRIM

Exploded View

INFOID:000000006046598

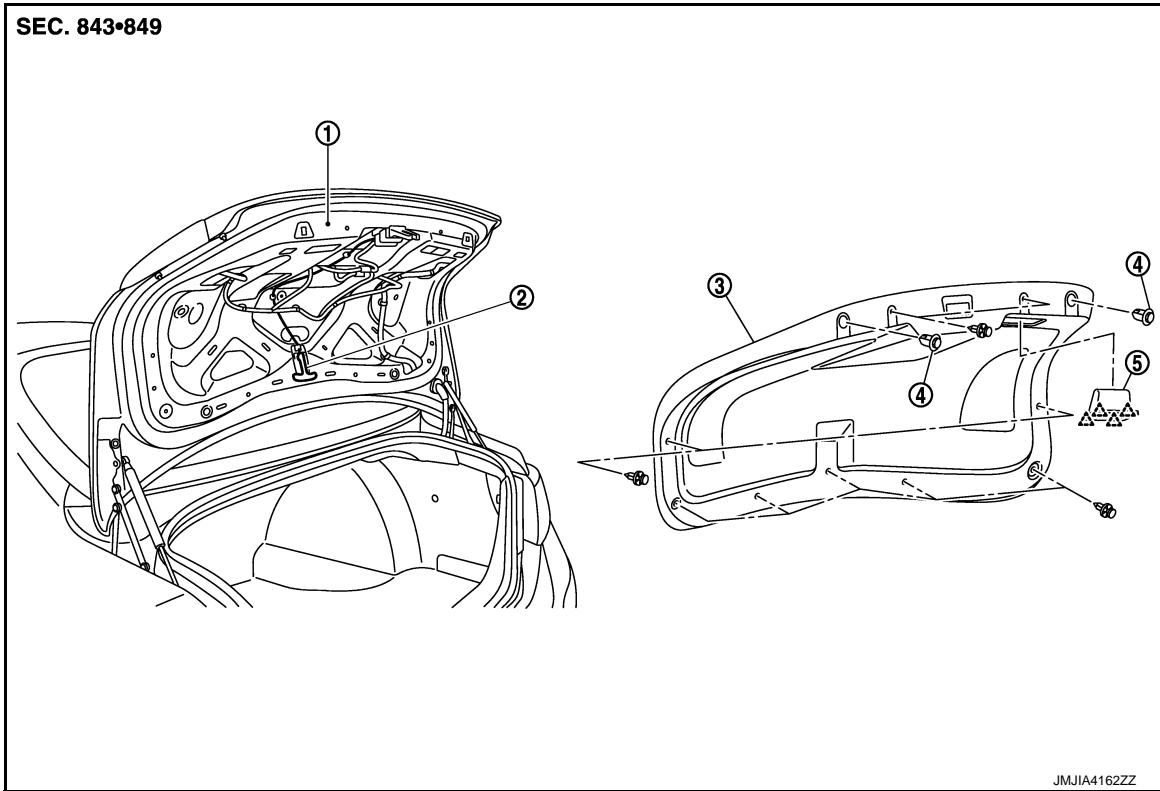

- 1. Trunk lid assembly
- 2. Emergency handle
- 3. Trunk lid inner finisher
- 4. Trunk lid bumper rubber
- 5. Trunk lid pull handle

 : Pawl

Removal and Installation

INFOID:000000006046599

REMOVAL

1. Fully open trunk lid assembly.
2. Disengage trunk lid emergency handle holder (1) fixing clips.

 : Clip

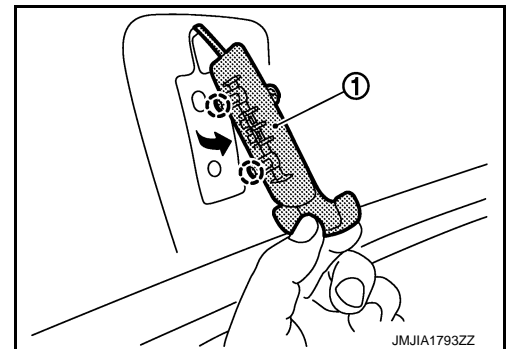

3. Remove trunk lid bumper rubber.

TRUNK LID TRIM

< REMOVAL AND INSTALLATION >

1. Insert a remover tool between trunk lid bumper rubber and trunk lid assembly and disengage pawls.
2. Pull back trunk lid bumper rubber.

 : Pawl

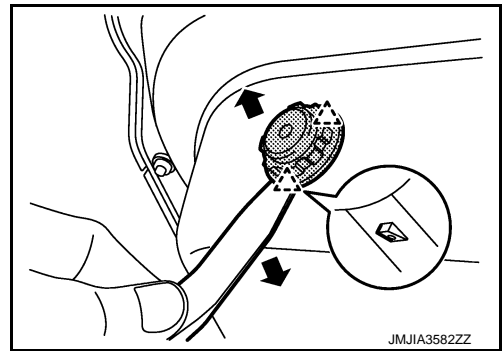

4. Remove trunk lid pull handle.

1. Insert a remover tool between trunk lid pull handle (1) and trunk lid assembly and disengage pawls.
2. Pull down trunk lid pull handle.

 : Pawl

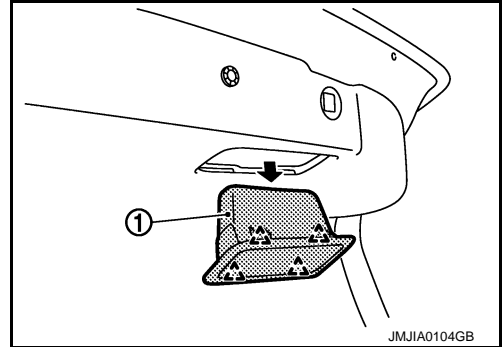

5. Remove trunk lid inner finisher fixing clips, and then remove trunk lid inner finisher.

INSTALLATION

Install in the reverse order of removal.

A
B
C
D
E
F
G
H
I
K
L
M
N
O
P

INT

REAR SUNSHADE ASSEMBLY

< REMOVAL AND INSTALLATION >

REAR SUNSHADE ASSEMBLY

Exploded View

INFOID:000000006113020

Refer to [INT-43, "Exploded View"](#).

Removal and Installation

INFOID:000000006113023

REMOVAL

CAUTION:

When removing and installing, use shop cloths to protect parts from damage.

1. Remove trunk lid inner finisher. Refer to [INT-56, "Removal and Installation"](#).
2. Disconnect rear sunshade control unit connector.
3. Remove rear parcel shelf finisher. Refer to [INT-43, "Removal and Installation"](#).
4. Remove bolts.
5. Pull rear sunshade assembly toward vehicle front and disengage clips.
6. Pull rear sunshade assembly upward to remove.

INSTALLATION

Note the following item, and then install in the reverse order of removal.

CAUTION:

Be sure to clump the harness to the right place.

REAR SUNSHADE SWITCH

< REMOVAL AND INSTALLATION >

REAR SUNSHADE SWITCH

Exploded View

INFOID:000000006113021

Refer to [IP-12. "Exploded View"](#).

Removal and Installation

INFOID:000000006113024

REMOVAL

CAUTION:

When removing and installing, use shop cloths to protect parts from damage.

1. Remove instrument lower panel LH. Refer to [IP-13. "Removal and Installation"](#).
2. Disconnect twin switch connector.
3. Remove screws.
4. Remove switch panel from instrument panel LH.
5. Remove rear sunshade switch from switch panel using flat-bladed screwdriver etc.

INSTALLATION

Note the following item, and then install in the reverse order of removal.

CAUTION:

Be sure to clump the harness to the right place.

A
B
C
D
E
F
G
H
I
K
L
M
N
O
P

INT